



Renewable and Nonrenewable Energy

Vol: 5(1), 2026

REST Publisher; ISBN: 978-81-948459-2-8

Website: <https://restpublisher.com/book-series/ese/>

DOI: <https://doi.org/10.46632/rne/5/1/7>

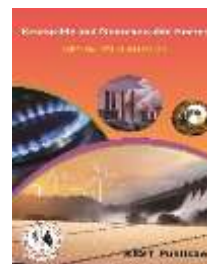

Design & simulation of VSD Based Solar Pump Controller for Irrigation Needs

K. Kalyani Radha, B. Omprakash

JNTUACEA, Ananthapuramu, Andhra Pradesh, India.

*Corresponding Author Email: radha.mech@jntua.ac.in

Abstract: A new generation solar Photovoltaic (PV) based solution designed for medium head water pumping applications is evaluated in this paper. The primary use of this pump is to providing water for remote agricultural usage. In all tests, the pump is connected to a 3 phase solar pump controller which is a combination of motor and inverter, Maximum Power Point Tracker (MPPT) and Variable Speed Drive (VSD) mainly targeted for solar pumping systems for irrigation. The water pumping system proposed in this paper is a photovoltaic stand-alone AC water pumping system without backup batteries. The main of this paper is to design and operate a solar AC water pumping system for medium head water pumping requirements. The pump running on a specially designed 3- Φ , 230 Vac induction motor is considered for this purpose. The PV and pump characteristics are observed with different solar radiations. A computational experiment system is developed by using Mat Lab/Simulink.

Keywords: Variable Speed Drive, Maximum Power Point Tracker, 1-axis tracking, solar PV, three phase 220V pump, solar irradiance, sustainable agriculture.

1. INTRODUCTION

Photovoltaic powered systems are becoming increasingly popular due to The environmental degradation caused by the fossil fuel based power plants and ever rising cost of fossil fuel based electricity and the absence of the power line near the water pumping sites in remote areas, frequent shortage of electrical power and hence failure to meet the ever rising load demand and also fast declining cost of PV electricity. One of the potential applications in the use of PV power is in water pumping systems for irrigation directly without any energy storage during the day time, and large scale promotion of these pumps may help to bring down the load on the fossil fuel based power plants to great extent. A PV powered water pumping system consists of different subsystems i.e. PV array, Maximum Power Point Tracker, Variable Speed Drive (speed controller), motor and pump. The performances of these subsystems vary with input PV power levels, which is a function of solar radiation and the load demand on the pump and to a certain extent on the ambient temperature. As a result, overall performance of the system keeps continuously varying throughout the day right from sunrise to sunset. Overall efficiency figure at any given instant may be obtained by combining the efficiency figures of subsystems. The efficiency of motor-pump set is governed by the manufacturer designed operating point and operating conditions at the site. Performance indices are established for the overall system. Different subsystem behaviours under varying irradiation (sunrise to sunset) are also studied and presented. A three phase induction motor based pump is considered for operation, as VSD's output is three phase [1].

2. PROPOSED SYSTEM

The block diagram explains overview of proposed system and the Variable Speed Drive has advantage of operating with PV Array and Grid Supply by using change over switch, the VSD is combination of DC-DC Boost converter with MPPT and Pump controller [1].

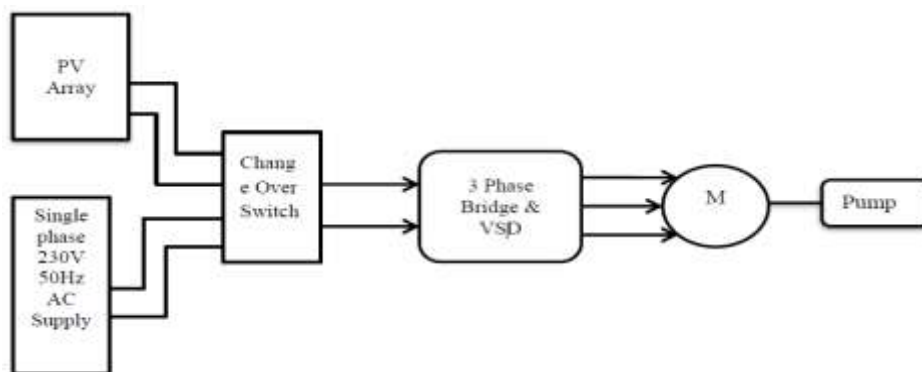

FIGURE 1. Block Diagram of Proposed System

The power supply to Variable Speed Drive is given from PV array or Single Phase supply through change over switch, during sunshine hovers the supply is taken from PV supply and during non-sunshine hovers the supply is taken from Single Phase Grid Supply.

Operation with PV System

The energy produced by the solar panel is fed to the pump trough a converter with two power stages

- DC-DC Boost converter with MPPT
- Pump controller (converts DC voltage to three phase AC voltage set)

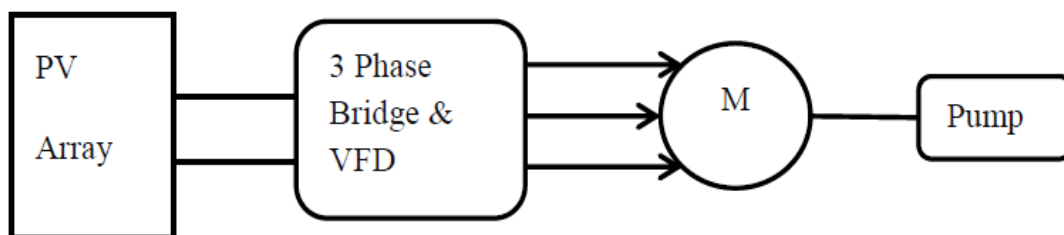

FIGURE 2. Block Diagram of Pump with PV Array

Operation with grid (1-ø ac) supply

The power from single phase supply is fed to pump through a converter with two power stages [3] [4].

- Diode rectifier with boost converter
- Pump controller (converts DC voltage to three phase AC voltage set)

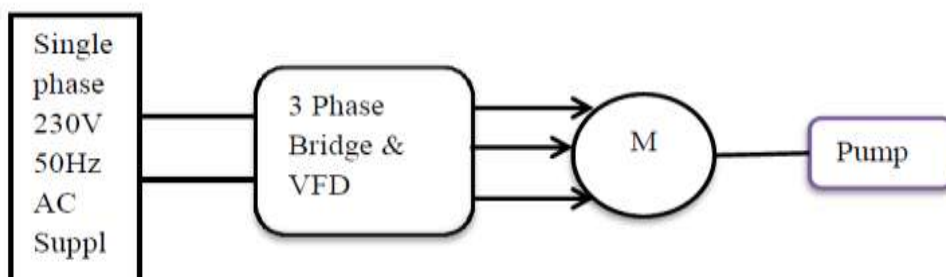

FIGURE 3. Block Diagram of Pump with Grid Supply

3. PV SYSTEM

PV Modules collect solar radiation from the sun and actively convert that energy to electricity. Are comprised of several individual solar cells and function similarly to large semiconductors and utilize a large-area p-n junction diode. When the solar cells are exposed to sunlight, the p-n junction diodes convert the energy from sunlight into usable electrical energy [5] [6]. The energy generated from photons striking the surface of the allows electrons to be knocked out of their orbits and released, and electric fields in the solar cells pull these free electrons in a directional current (D.C.), from which metal contacts in the solar

cell can generate electricity. The more solar cells in a PV Module and the higher the quality, the more total electrical output the PV Module can produce. The conversion of sunlight to usable electrical energy is otherwise known as the Photovoltaic Effect. The photovoltaic effect arises from the properties of the p-n junction diode, as such there are no moving parts in a Factors that affect the output of are weather conditions, shade caused by obstructions to direct sunlight, and the angle and position at which the PV Module is installed. PV Modules delivers the best output when placed in direct sunlight, away from obstructions that might cast shade, and in areas with high regional solar insolation ratings. PV Module efficiency can be optimized by using dynamic mounts that follow the position of the sun in the sky and rotate the PV Module to get the maximum amount of direct exposure during the day as possible. *Simulation of Solar panel:* A simple modeling is chosen for MATLAB modeling and

Simulation. A simple PV cell is represented by a light dependent current source (I_{sc}) in antiparallel with a diode driven by current I_d [2] and a series resistance in the current path through semiconductor material, the metal grid, contacts and current collecting bus [4][5]. The presence of diode determines the output V-I characteristics of solar cell. The parallel resistance associated with a small leakage of current through a resistive path in parallel with an intrinsic device [5][6] is very large, so its effect is very less and is neglected. The equations which govern the characteristics of solar cell are:

$$I = I_{sc} - I_o \left[e^{q(V+IR_s)/nKT} - 1 \right] \tag{1}$$

$$I_{sc} |_G = \left(\frac{G}{G_o} \right) I_{sc} |_{G_o} \tag{2}$$

$$I_o |_T = I_{sc} |_{T_{ref}} \left(\frac{T}{T_{ref}} \right)^{3/n} e^{-\left(\frac{qE_g}{nK} \right) \left(\frac{1}{T} - \frac{1}{T_{ref}} \right)} \tag{3}$$

$$I_{sc} |_T = I_{sc} |_{T_{ref}} [1 + a(T - T_{ref})] \tag{4}$$

$$I = I_{sc} - I_o \left[e^{q(V+IR_s)/nKT} - 1 \right] - \frac{V + IR_s}{R_p} \tag{5}$$

$$R_s = - \left(\frac{dV}{dI} \right) - \frac{nKT/q}{I_o \left[e^{q(V+IR_s)/nKT} - 1 \right]} \tag{6}$$

The single diode equivalent electrical circuit of solar cell is shown in fig 4 the solar cell is constructed in MATLAB by using current source and diode here R_s (m Ω) is series resistance of solar cell which is very small to allow maximum current, R_{sh} (K Ω) is parallel resistance of solar cell and I_{RR} is solar radiation in W/m².

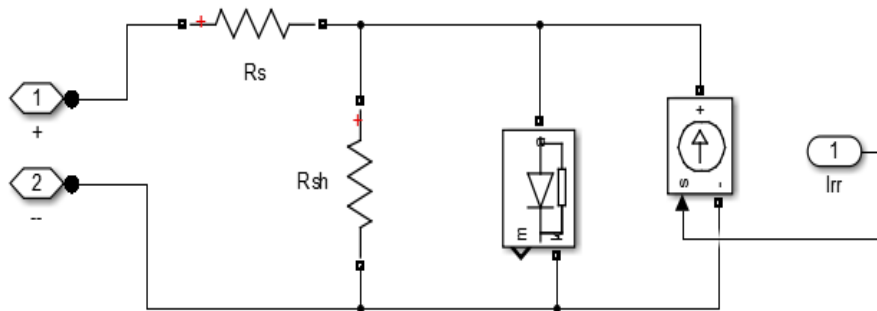

FIGURE 4. Equivalent circuit for solar cell in MATLAB simulation

4. DC-DC BOOST CONVERTER WITH MPPT ALGORITHM

DC-DC boost converter: Boost converter steps up the input voltage magnitude to a required output voltage magnitude without the use of a transformer. The main components of a boost converter are an inductor, a diode and a high frequency switch. These in a coordinated manner supply power to the load at a voltage greater than the input voltage magnitude. The control strategy

lies in the manipulation of the duty cycle of the switch which causes the voltage change [8]. There are two modes of operation of a boost converter. Those are based on the closing and opening of the switch. The first mode is when the switch is closed; this is known as the charging mode of operation. The second mode is when the switch is open; this is known as the discharging mode of operation

- Charging Mode
- Discharging Mode

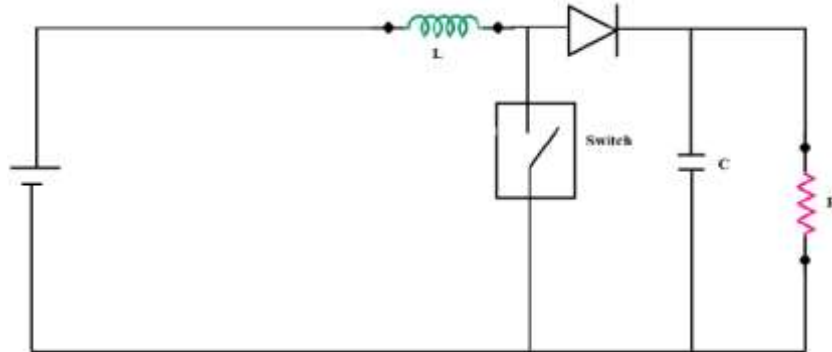

FIGURE 5. Circuit Diagram of DC-DC Boost Converter

Charging Mode: In this mode of operation; the switch is closed and the inductor is charged by the source through the switch. The charging current is exponential in nature but for simplicity is assumed to be linearly varying. The diode restricts the flow of current from the source to the load and the demand of the load is met by the discharging of the capacitor *Discharging Mode:* In this mode of operation; the switch is open and the diode is forward biased. The inductor now discharges and together with the source charges the capacitor and meets the load demands. The load current variation is very small and in many cases is assumed constant throughout the operation [7]

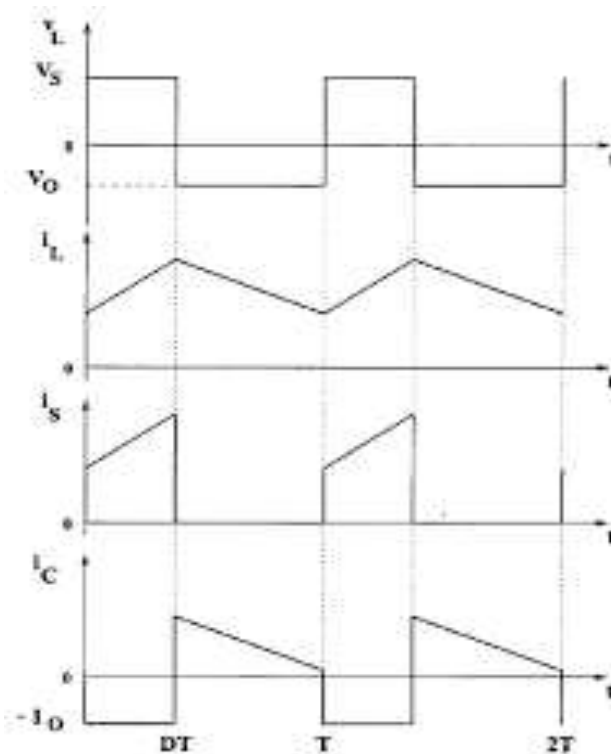

FIGURE 6. Wave forms of Boost Converter

Implementation of MPPT using a boost converter

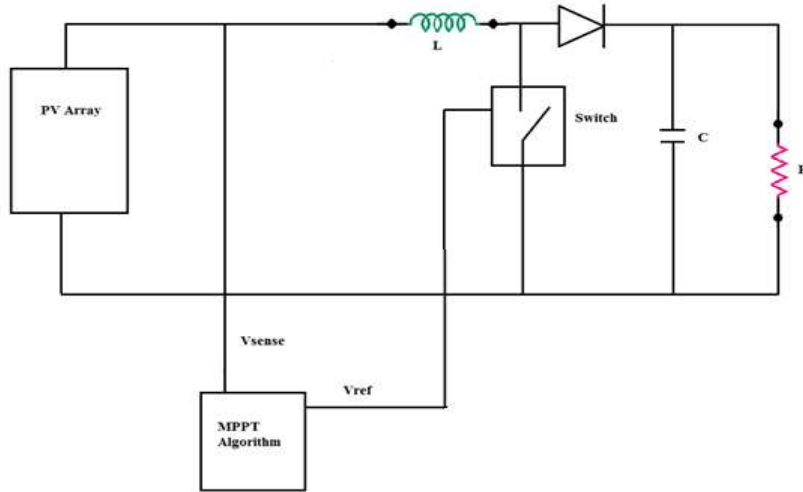

FIGURE 7. Circuit Diagram of Boost converter with MPPT

MPPT Algorithm: The Perturb & Observe method implements a hill climbing technique, which works well in slow changing Environment but has some limitations under rapidly changing atmospheric conditions. The methods may lead to incorrect or slow maximum power point tracking. To overcome such problems, the Perturb & Observe method, isolates the fluctuations caused by the perturbation process from those caused by the irradiance or weather change. This method adds an irradiance-changing estimate process in every perturb process to measure the amount of power change caused by the change of atmospheric condition. Because the estimate process stops tracking maximum power point by keeping the PV voltage constant, the tracking speed of Perturb & Observe method is only half of the conventional Perturb & Observe method [7] [9].

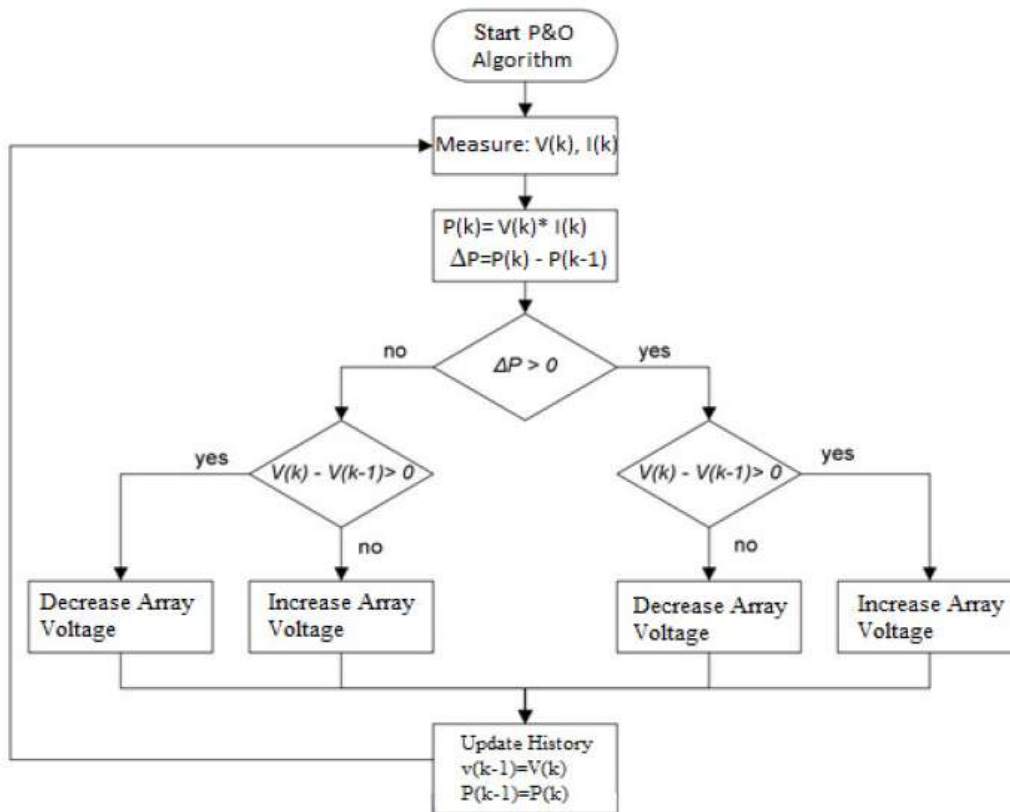

FIGURE 8. Perturb & Observe MPPT Algorithm

5. VARIABLE SPEED DRIVE (VSD)

With the arrival of power electronics, new impulse was given to variable speed applications of AC machine. The former typically use thyristor controlled rectifiers to provide high performance torque, speed and flux control. Variable speed IM drives

use mainly PWM techniques to generate a polyphase supply of a given frequency. Most of these induction motor drives are based on keeping a constant voltage/frequency (V/f) ratio in order to maintain a constant flux in the machine. Although the control of V/f drives is relatively simple, the torque and flux dynamic performance is extremely poor. The controlling technique used is constant torque Sensor less flux vector control with PWM type motor control [13].

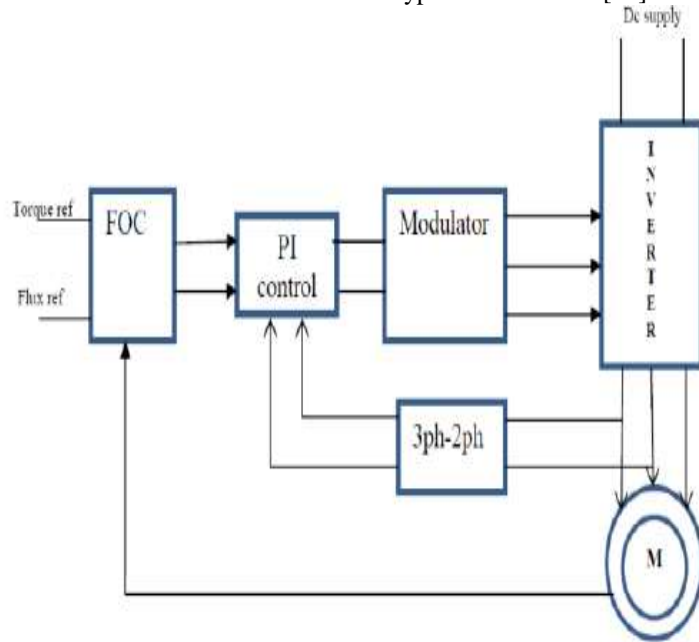

FIGURE 9. Block Diagram of Variable Speed Drive

The fig 9 shows the internal circuit of Variable Speed Drive the control technique used is Sensor Less Field Orientation Control.

6. SIMULATIONS AND RESULTS

The simulation results of pump with single phase AC supply are

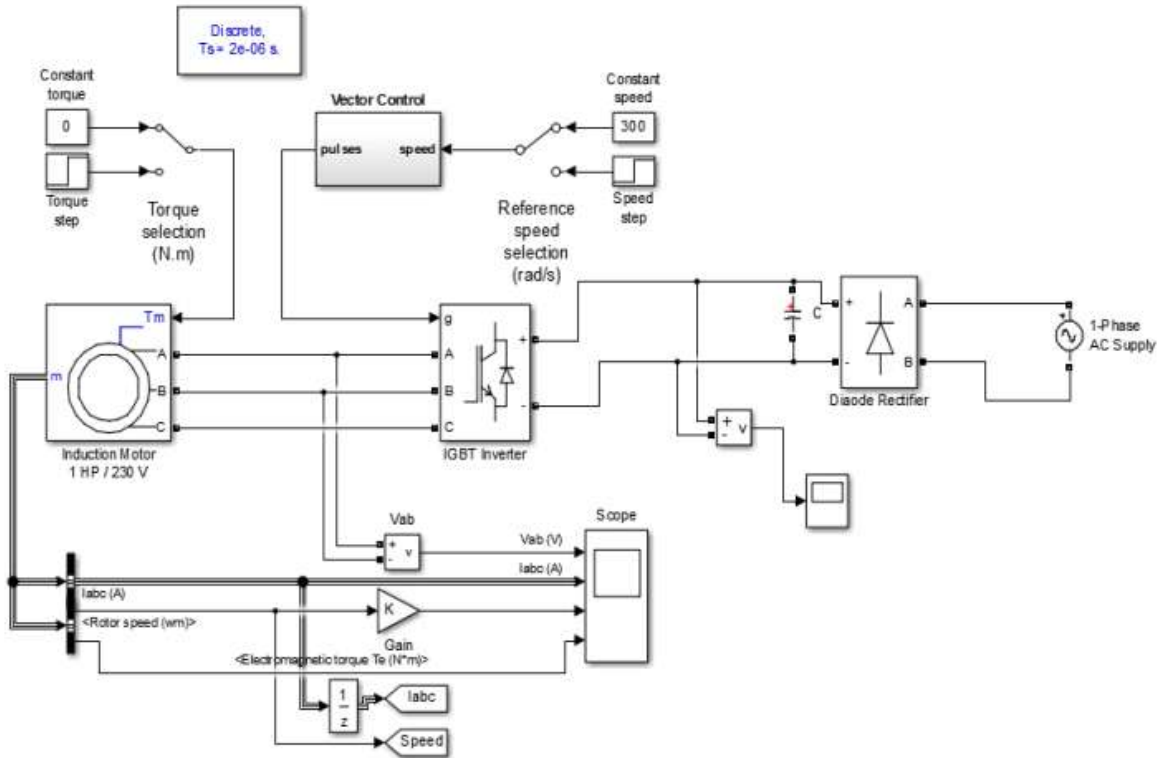

FIGURE 10. MATLAB Diagram of Pump with Single 1-ph 230V AC Supply

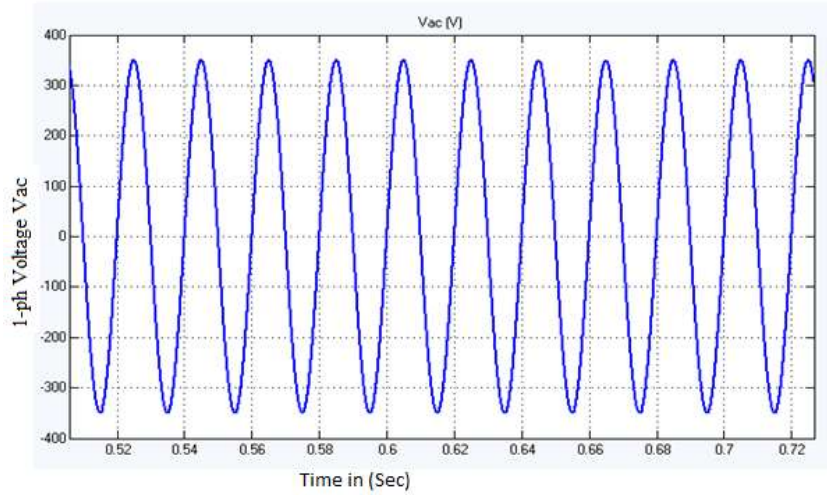

FIGURE 11. Single-phase 230V AC Supply Voltage

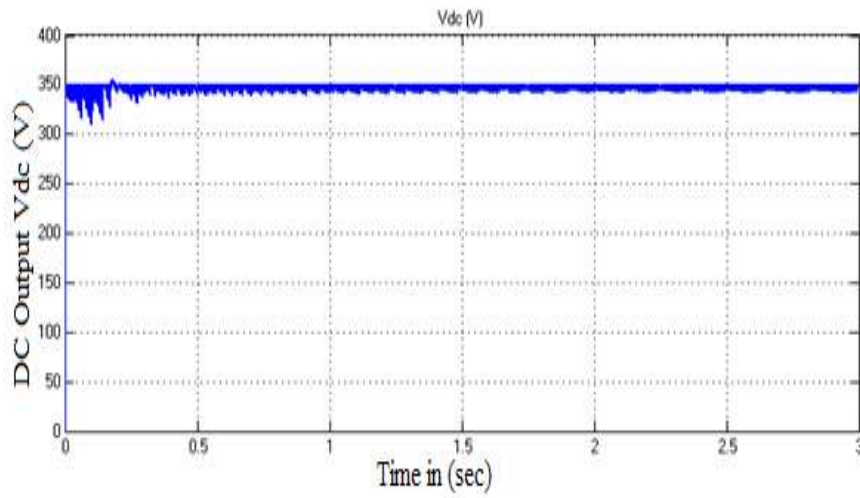

FIGURE 12. DC Voltage output from inverter

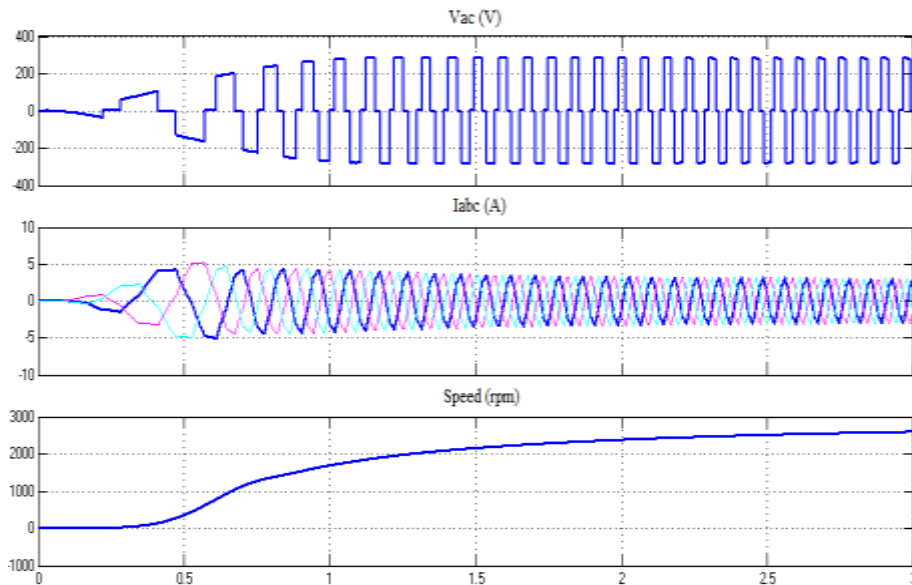

FIGURE 13. Output Waveforms of V, I, and Speed

The simulation results of pump with PV system are

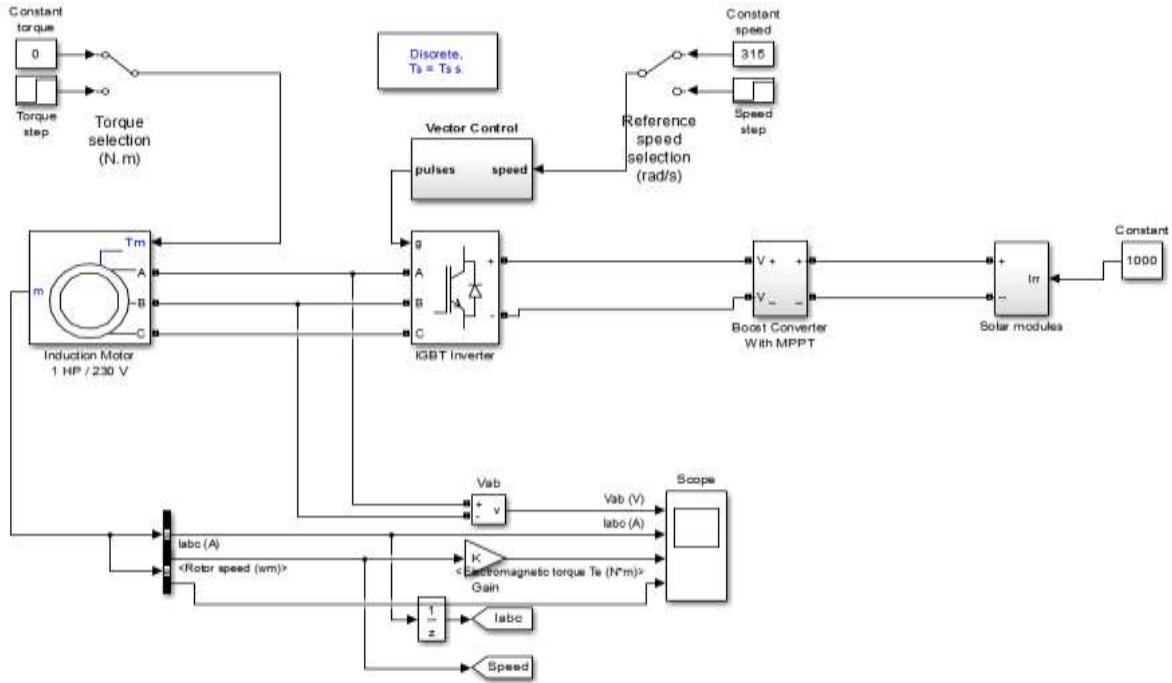

FIGURE 14. Simulation Diagram of Pump with PV system

At Solar Radiation 1000W/m^2

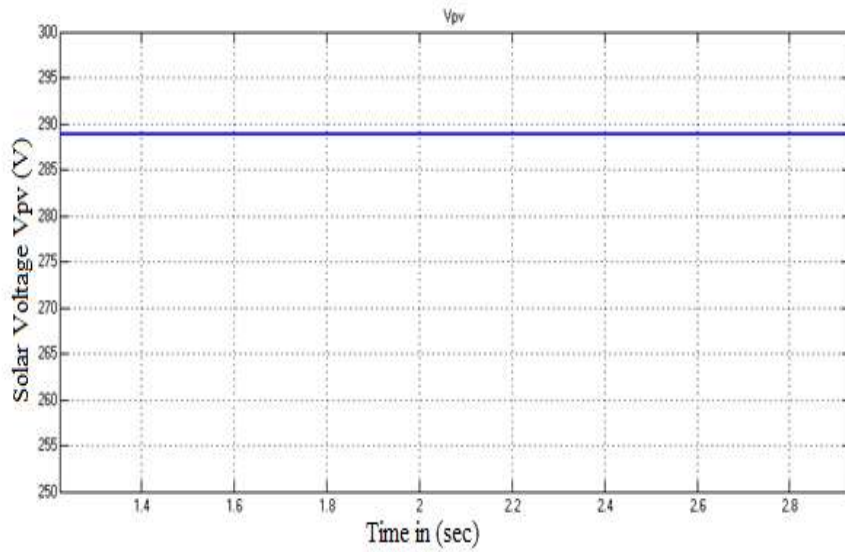

FIGURE 15. PV Voltage Vpv in Volts

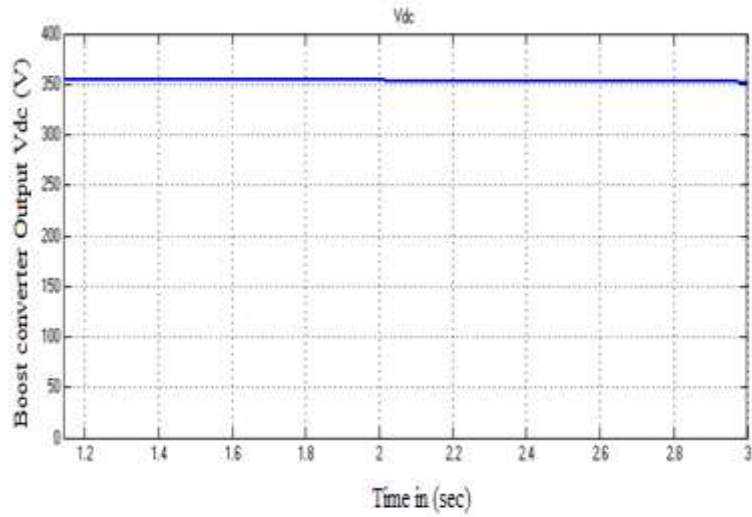

FIGURE 16. PV Voltage Vpv in Volts

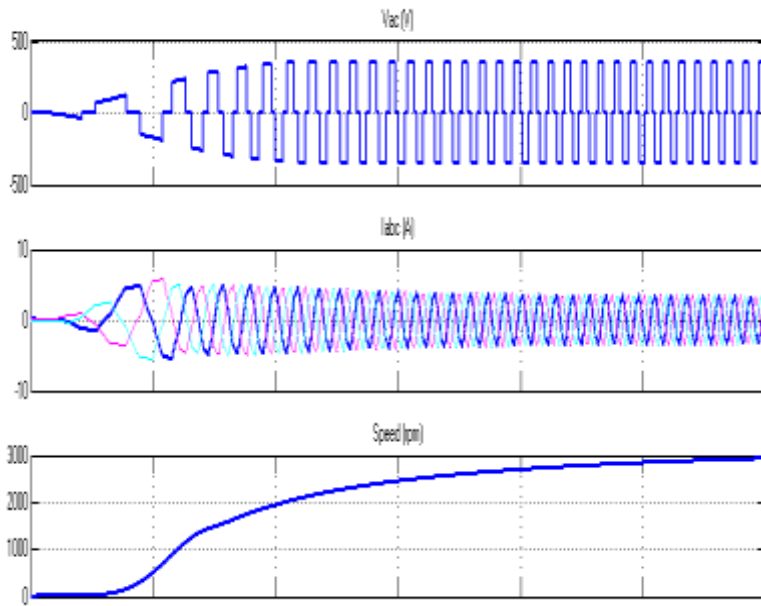

FIGURE 17. Output Waveforms of V, I, and Speed

At Solar Radiation $800W/m^2$

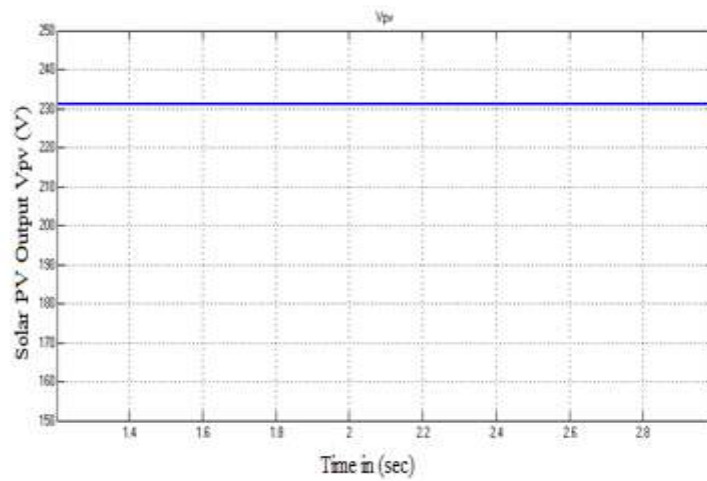

FIGURE 18. PV Voltage Vpv in Volts

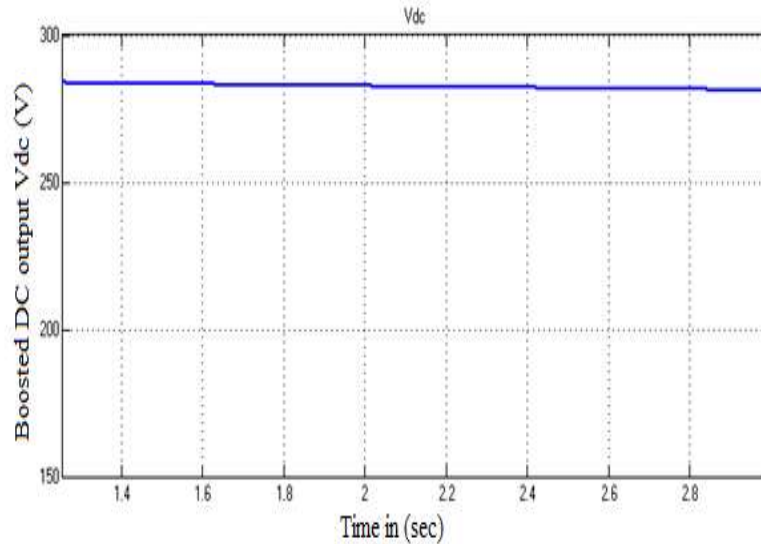

FIGURE 19. PV Voltage V_{pv} in Volts

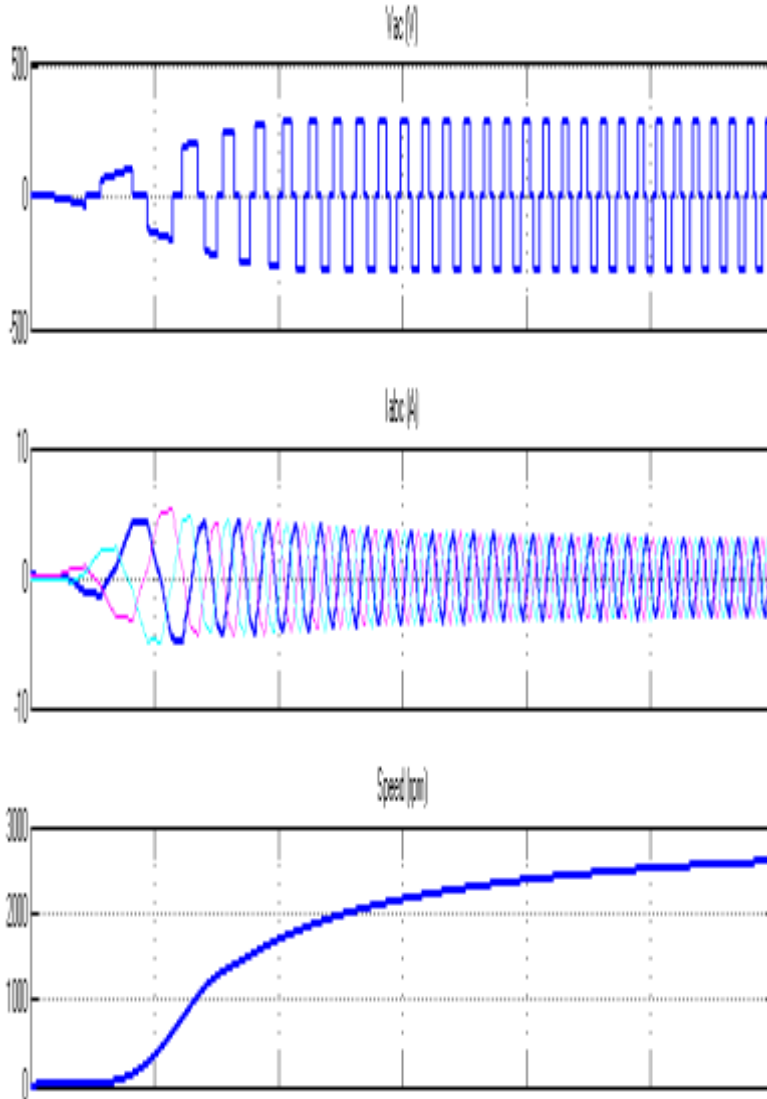

FIGURE 20. Output Waveforms of V, I, and Speed

The simulation Results are tabulated as:

TABLE 1: Simulated results of pump with solar operation

Irradiation in W/m ²	Solar PV Voltage V _{pv} in Volts	Boosted Voltage V _{dc} in Volts	AC Voltage V _{ac} Output in Volts	Frequency in HZ	Speed in Rpm
1000	288.8	351.9	234.6	48.69	2921
950	274.4	334.2	228.6	47.34	2840
900	260	316.5	223.8	46.95	2757
850	245.6	398.9	211.3	44.52	2671
800	231.2	281.2	198.84	43.05	2583
750	216.8	263.5	186.32	41.52	2491
700	202.4	245.8	173.8	39.93	2396
650	188	228.1	161.29	38.28	2297
600	173.6	210.5	148.84	36.55	2193
550	159.2	192.8	136.33	34.75	2085
500	144.8	175.1	123.81	32.84	1970
450	130.4	157.4	111.3	30.82	1849
400	116	139.7	98.78	28.66	1719
350	101.6	122	86.26	26.33	1580
300	87.19	104.3	73.75	23.79	1427
250	72.8	86.62	61.25	20.96	1258

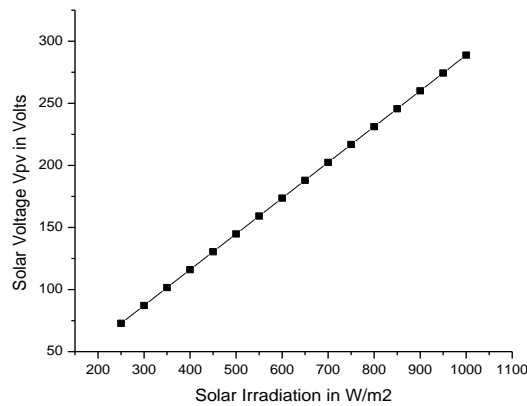

FIGURE 21. Solar voltage Vs Solar irradiation

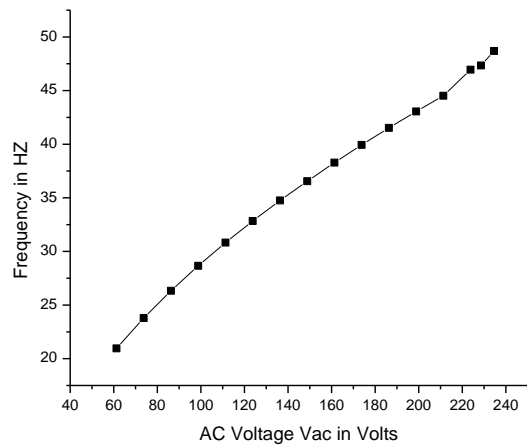

FIGURE 22. Plot of Frequency Vs AC voltage output

7. CONCLUSION

The model used for simulations of AC water pump gives results within a reasonable range. The accuracy of model is, uncertain because the parameters are only estimates. If tests could be run on the real water pump motor or an equivalent sized motor to determine reasonable entries to SIMULINK block parameters, this could lead to more accurate simulation runs. Also, simply increasing the size of system and using a larger motor could allow for better results in SUMILINK, though many PV water pumps rarely use such large motors. From the simulation results the variations in pump characteristics are observed with variations in solar irradiation. Thus, Solar PV powered pump solutions be a one- stop solution for sustainable agriculture.

REFERENCES

- [1] Victor M. Caracas, Luis Felipe M. Teixeira, Guilherme de C. Farias, Luiz A. de S. Ribeiro "Implementation of a High efficiency and low Cost Converter for a Photovoltaic Water Pumping System" Institute of Electrical Energy Federal University of Maranhao Sao Luis, Brazil 978-1-4577-1216-6/12/\$26.00 ©2012 IEEE
- [2] Reddy, B.R.S. Jambholkar, P. Narayana, P.B.Reddy, K.S." MPPT algorithm implementation for solar photovoltaic module using microcontroller ", India Conference (INDICON), 2011 IEEE publication
- [3] Sadasivam, P; Kumaravel, M.; Vasudevan, K.; Jhunjhunwala, A." Analysis of subsystems behaviour and performance evaluation of solar photovoltaic powered water pumping system" published in Photovoltaic Specialists Conference (PVSC), 2013 IEEE39th.
- [4] M. G. Villalva, J. R. Gazoli, E. Ruppert F, "Comprehensive approach to modeling and simulation of photovoltaic arrays", IEEE Transactions on Power Electronics, 2009 vol. 25, no. 5, pp. 1198--1208, ISSN 0885-8993.
- [5] R. Sridhar, Dr.Jeevananathan, N. ThamizhSelvan, Saikat Banerjee, "Modeling of PV Array and Performance Enhancement by MPPT Algorithm", International Journal of Computer Applications (0975 – 8887) Volume 7– No.5, September 2010.
- [6] MummadiVeerachary, "Control of TI-SEPIC Converter for Optimal Utilization of PV Power", IICPE, 2010 New Delhi.
- [7] R. Sridhar, Dr.Jeevananathan, N. ThamizhSelvan, Saikat Banerjee, "Modeling of PV Array and Performance Enhancement by MPPT Algorithm", International Journal of Computer Applications (0975 – 8887) Volume 7– No.5, September 2010.
- [8] M. Berrera, A. Dolara, R. Faranda and S. Leva, "Experimental test of seven widely-adopted MPPT algorithms", 2009 IEEE Bucharest Power Tech Conference, June 28th - July 2nd, Bucharest, Romania.
- [9] P. S. Revankar, W. Z. Gandhare and A. G. Thosar Government College of Engineering, Aurangabad, "Maximum Power Point Tracking for PV Systems Using MATLAB/SIMULINK", 2010 Second International Conference on Machine Learning and Computing.
- [10] Ramos Hernanz, JA., Campayo Martín, J.J. Zamora Berver, I., LarrañagaLesaka, J., Zulueta Guerrero, E. Puelles Pérez, E.," Modeling of Photovoltaic Module", International Conference on Renewable Energies and Power Quality (ICREPQ'10) Granada (Spain), 23th to 25th March, 2010.
- [11] ArunKumarVerma, Bhim Singh and S.C Kaushik, " An Isolated Solar Power Generation using Boost Converter and Boost Inverter," in Proc. National Conference on Recent Advances in Computational Technique in Electrical Engineering, SLITE, Longowal (India), 19-20 March, 2010, paper 3011, pp.1-8.
- [12] AthimulamKalirasu, SubharensuSekar Dash, "Simulation of Closed Loop Controlled Boost Converter for Solar Installation", Serbian Journal of Electrical Engineering Vol. 7, No. 1, May 2010, 121-130.
- [13] Scott Wade, Matthew W. Dunnigan, and Barry W. Williams, "Modelling and Simulation of Induction Machine Vector Control with Rotor Resistance Identification", IEEE transactions on power electronics, vol. 12, no. 3, may 1997.
- [14] D.W. Novotney, et al (editor), "Introduction to Field Orientation and High Performance AC drives", IEEE IAS tutorial course, 1986.