



Renewable and Nonrenewable Energy

Vol: 5(1), 2026

REST Publisher; ISBN: 978-81-948459-2-8

Website: <https://restpublisher.com/book-series/ese/>

DOI: <https://doi.org/10.46632/rne/5/1/5>



Development of Transformer less Single Phase Voltage Source Inverter for Distribution Generation System

*K Kalyani Radha, B Omprakash

JNTUACEA, Ananthapuramu, Andhra Pradesh, India.

*Corresponding Author Email: radha.mech@jntua.ac.in

Abstract: Solar energy, received in the form of radiation (electromagnetic waves), can be converted directly or indirectly into other forms of energy, such as heat and electricity which can be utilized by man. Inverters are the devices usually solid state which change the array DC output to AC suitable voltage, frequency and phase to feed photo voltaic ally generated power into the power grid or local load. Solar energy is time dependent and intermittent energy resources. Inverter may also contain a suitable output step up transformer perhaps some filtering and power factor correction circuits and some power conditioning circuitry to initiate the battery charging and to prevent overcharging. Inverters of PV system based distributed generation (DG) are subjected to wide changes in the inverter input voltage, thus demanding a buck-boost operation of inverters. Further the inverter size, weight and cost is increased. It is designed transformer less inverter that can be operated over a wide dc input voltage range making it suitable for distributed generation applications. Depending on the pulsated DC reference signal the inverter output voltage wave form can varied with respect to the input voltage.

Keywords: Buck-Boost inverter, Distribution Generation Systems (DG), Reference signal, Transformer less inverters, PWM.

1. INTRODUCTION

Energy conversion devices which are used to convert sun light to electricity by the use of the photo voltaic effect are called "Solar cells". Inverters are the devices usually solid state which change the array DC output to AC suitable voltage, frequency and phase to feed photo voltaic ally generated power into the power grid or local load. Inverter may also contain a suitable output step up transformer for some filtering and power factor correction circuit. Renewable energy substitutes conventional fuels or distinct areas air and water heating and cooling, motor fuels, electricity generation. Photovoltaic systems (PV) that supply power directly to the grid are becoming more popular due to the cost reduction achieved from the lack of a battery subsystem. This design can be used in high power ranges providing high system flexibility [1]. Distributed generation (DG) systems are usually small modular devices which are nearby to electricity consumers. These include wind turbines, solar energy systems, fuel cells, micro gas turbines, and small hydro systems, as well as relevant control and energy storage systems. These systems normally need inverters as interfaces between their single phase loads and source [3].

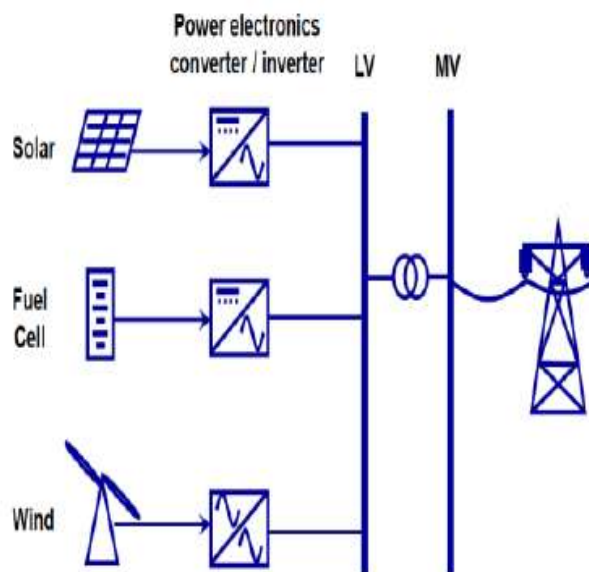

FIGURE 1. Renewable Energy Based DG system

Wind Energy Conversion System: The major components of a wind energy system include a wind turbine, generator, control system, gearbox, and interconnection apparatus. The kinetic energy produced by the wind is converted into mechanical energy by using wind turbine. The mechanical energy is converted into electrical energy by using generator. The functions of inverters for small DG systems can be summarized as follows [2].

- Inverter converts power conversion from variable dc voltage into fixed ac voltage for stand-alone applications and ac output in synchronism with the grid voltage and frequency for grid-connected applications.
- It converts variable DC voltage can be higher or lower than the ac voltage in a system, which is observed normally in solar energy and wind turbine systems. Thus, there is a need to buck boost the inverter voltage.

Depend on the electrical isolation between the output and input, inverters can be classified as isolated or non-isolated. Electrical isolation is normally achieved using either line-frequency or high-frequency transformers [1]. They are used for many applications, as in situations where low voltage DC sources such as batteries, solar panels or fuel cells should be converted so that devices can run off of AC power. The DC link voltage of inverters for DG systems may vary over a wide range. Depending upon the input dc voltage range in comparison to the output ac voltage, inverters can be buck inverters, boost inverters, or buck-boost inverters. Different DC voltages are applied to the inverter input because of the renewable energy sources, such as solar batteries and fuel cells, which produce different dc -voltage levels [4]. Normally, most topologies are boost or buck-boost due to two main factors. First one, pulse width modulation (PWM) produces an output voltage lower than the dc link voltage therefore, the dc link should be greater than the maximum possible ac output voltage. Second one, sometimes, independent of frequency, voltage step-up is necessary [5]. The transformer used for an inverter is a step-up type. Transformer must have very low resistance because of the high current involved, and in all cases transformer has to be designed for the mains frequency in use. This means that it will be comparatively large, at least the same size as a normal step-down transformer used for the same VA rating. Depending on the intended usage (permanently or intermittent connected for example) the allowable losses will be different. A transformer that will only be used for normal UPS duties may be smaller than the ideal case, and it will therefore be cheaper, smaller and lighter. Of course, it will also have higher losses. The primary inductance is of little real consequence, but it must be high enough to ensure that magnetizing current at 50Hz or 60Hz is low enough to ensure losses are within sensible limits.

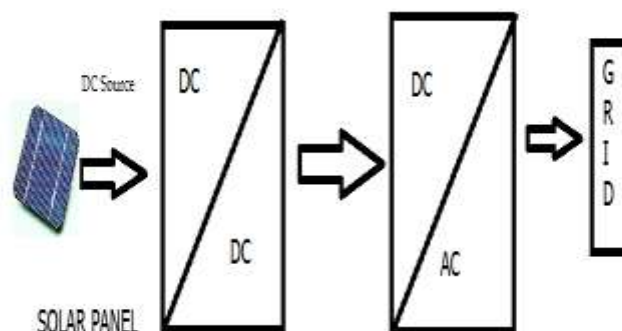

FIGURE 2.Block Diagram DC to AC

The boost converter is best if a significant and much step up is required, such as with a short string of 12-PV panels [6]. The Traditional full-bridge inverters do not have the flexibility of handling a wide range of *dc* input voltages. Especially when the DC voltage is lower than the Voltage, heavy line-frequency step-up transformers are required. Although these inverters show robust performance and high reliability, they demand higher volume, weight and cost for DG system applications [7]. A cascaded multilevel inverter consists of a series of H-bridge inverter devices. The work of multilevel inverter is to synthesize a desired voltage from Several Separate DC Source [6]. The main disadvantage of this system is that each single H-bridge cascaded inverter modules needs a separate DCsupply source [9].

2. PROPOSED DC TO AC CONVERTER

The block diagram of boost inverter used for the proposed system is shown in Fig 3. DC voltage obtained from the photo voltaic cells is given as input to dc-dc converter. Depending upon the reference value set, dc-dc converter boosts the input voltage DC voltage is converted to ac voltage by switching the switches of two arms of H-bridge complementarily.

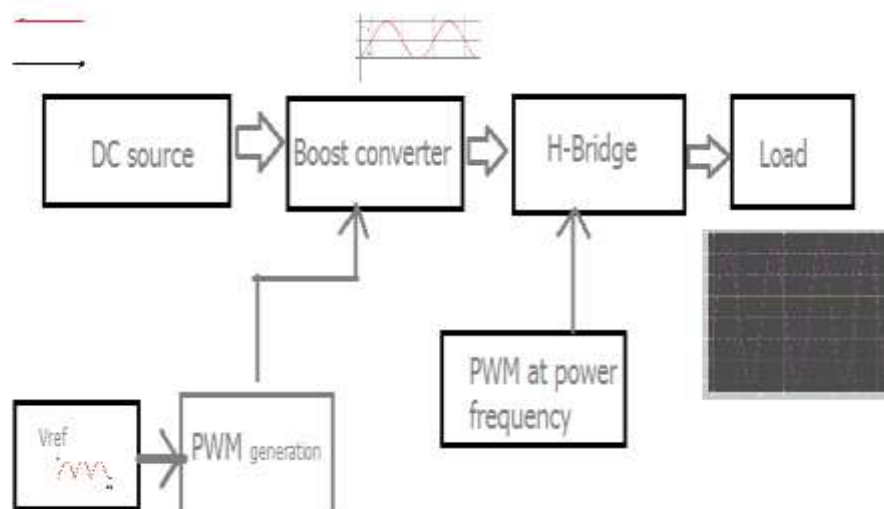

FIGURE 3.Block diagram of AC to DC converter

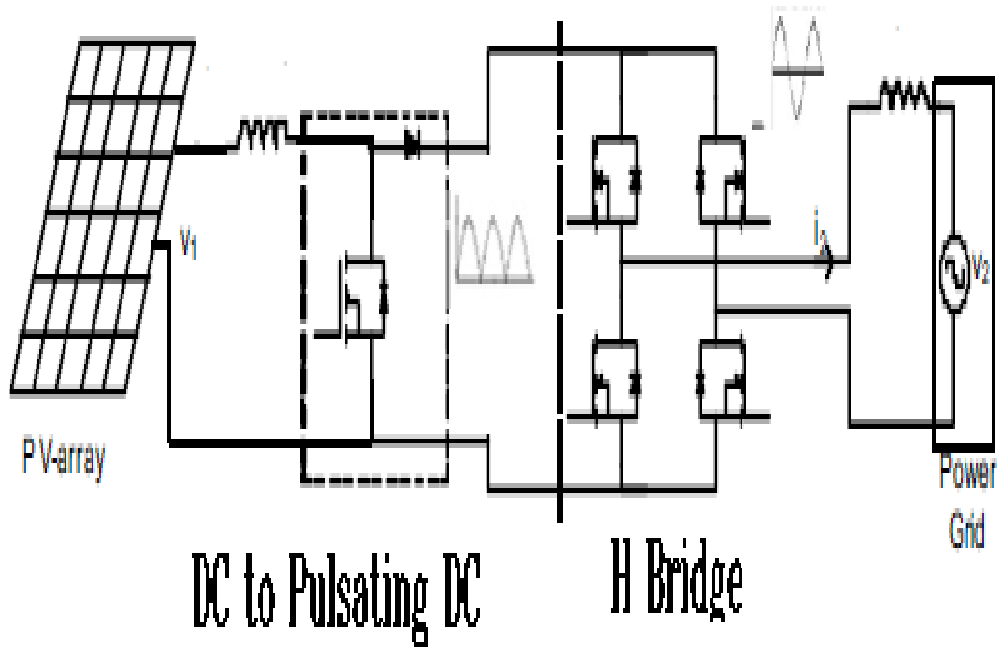

FIGURE 4. Proposed dc to ac converter

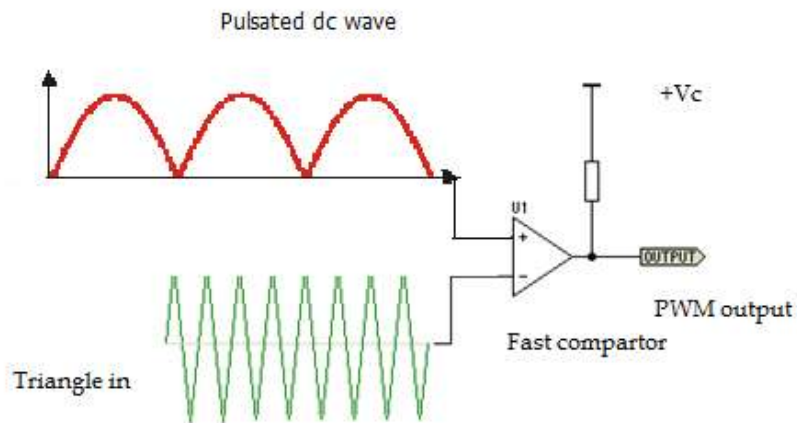

FIGURE 5. Generating PWM

Working Principle: Normally the Pulse Width Technique(PWM) uses the sine wave reference but it is proposed that triangular wave is taken as reference .The PWM output from the Figure(5) is triangular wave and is given to the mosfet 1 in the circuit diagram Figure(4). When the Switch 1 is closed .then inductor coil stores the energy from the source, When the switch is opened, inductor coil is releases the energy in the form of voltage, so that it is added to the source voltage thus boosts the output voltage.

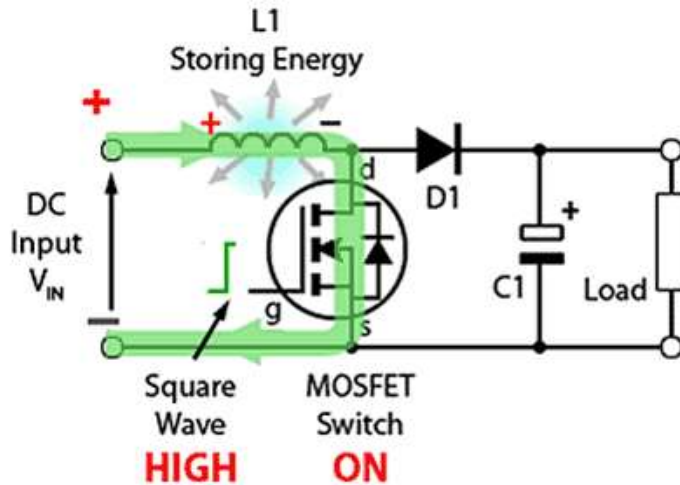

FIGURE 6. Inductor storing energy

The output from the dc to dc converter is as shown in Fig (7) is approximate pulsated dc wave.

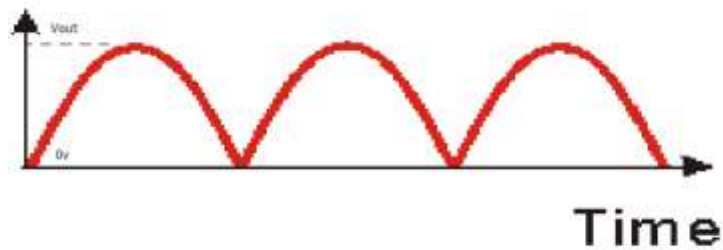

FIGURE 7. Output from DC to DC converter

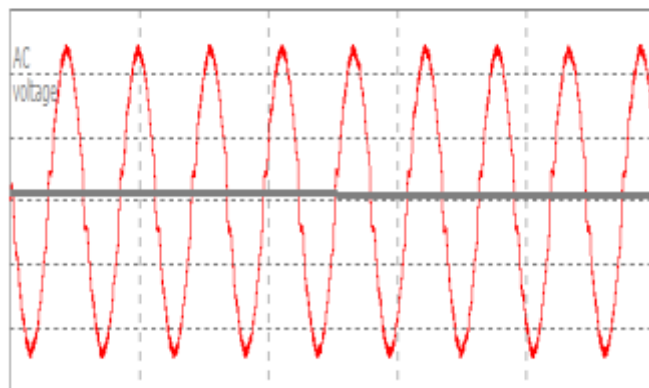

FIGURE 8. Output wave from H-Bridge

The output from boost converter is pulsated dc wave is given to the H Bridge inverter as shown in the Figure (8). The output from the dc to dc converter is fed to the H Bridge which is consists of four Mosfets.

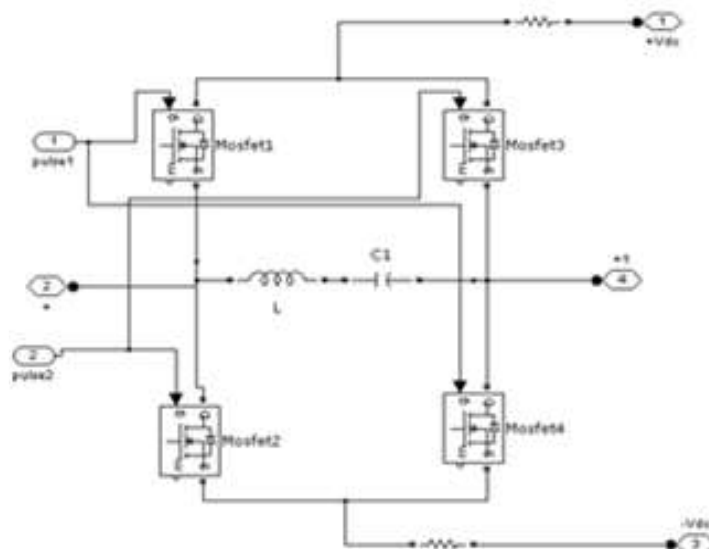

FIGURE 9. H-Bridge schematic diagram

The implementation of this circuit is done. The system Parameters of the circuit to generate pulsated DC wave from integrated circuit logic inverter 74hc14 are in table (1).

TABLE 1. System Parameters

Power frequency	Capacitance	Resistance
60Hz	.1uf	220 ohms
50Hz	.1uf	196 ohms

The proposed design of the inverter is implemented using boost converter and PWM generator. The input voltage is varied from 1V to 30V. The output voltage is varies from 85 to 105V (lower rated devices used for implementation, XL6009 voltage regulator) with corresponding input voltage. The circuit working is examined are in Table (2).



FIGURE 10. Experimental setup

3. RESULTS

It is implemented and validated the proposed design of circuit. The summary of results are given in Table (2).

TABLE 2. Summary of Results

S. No	V _{in} (V)	V _{out} (V)
1	5	110
2	8	110
3	12	110

In this case, designed circuit of the inverter circuits acts as a boost inverter since the reference pulsated dc wave is set to maximum, so that voltage is constant. The implemented inverter acts as boost inverter converting 10 volts to 105 volts. It is observed that the output voltage is remains same when further increase in input voltage from 5V.

4. CONCLUSION

From the results it is seen that designed boost single phase voltage inverter works well producing an ac wave outputs depending upon the reference signal. From the summary table it can be summarized that proposed design of the inverter circuit operates for wide voltage range of the dc input voltage producing a sinusoidal ac voltage 50Hz. The proposed design uses only five switches, the low switching frequency of the output H-bridge reduces the inverter switching losses and cost compared to multilevel inverters. The drawbacks of the inverter, compared to traditional H Bridge inverters are relatively high cost (switches) and relatively high switching losses in one of the five switches.

REFERENCES

- [1] T. G. Wilson, "The evolution of power electronics," IEEE Trans. Power Electron., vol. 15, pp. 439–446, May 2000.
- [2] Channaveer.P.Malad, K.Uma Rao" Simulation of a Buck-Boost Single Phase Voltage Source Inverter for Distribution Generation Systems" International Journal of Modern Engineering Research (IJMER), Vol.2, Issue.5, Sep.-Oct. 2012 pp-3628-3632.
- [3] Roman, I.T. "A single-phase current-source inverter with active power filter for grid-tied PV systems", 3rd IEEE International Symposium on Power Electronics for Distributed Generation Systems (PEDG), Aalborg, pp. 349-356, June 2012.
- [4] Ahmed Mohamed Salamah, Stephen J. Finney "Single-Phase Voltage Source Inverter with a Bidirectional Buck–Boost Stage for Harmonic Injection and Distributed Generation" IEEE transactions on power electronics, vol. 24, no. 2, pp 376- 387, February 2009.
- [5] R. Gonzalez, E. Gubia, J. Lopez, and L.Marroyo, "Transformerless single phase multilevel-based photovoltaic inverter," IEEE Trans. Ind. Electron., vol. 55, no. 7, pp. 2694–2702, Jul. 2008.
- [6] Geoffrey R. Walker, Member, IEEE, and Paul C. Sernia IEEE TRANSACTIONS ON POWER ELECTRONICS, VOL. 19, NO. 4, JULY 2004 Cascaded DC–DC Converter Connection of Photovoltaic Modules.
- [7] X. Yaosuo, C. Liuchen, B. K. Kjaer, J. Bordonau, and T. Shimizu, "Topologies of single-phase inverters for small distributed power generators: An overview," IEEE Trans. Power Electron., vol. 19, no. 5, pp. 1305–1314, Sep. 2004.
- [8] M. Calais, J. Myrzik, T. Spooner, V. G. Agelidis, "Inverter for Single-Phase Grid Connected Photovoltaic Systems – An Overview," Power Electron. Spec. Conf., Vol. 4, pp. 1995-2000, Feb. 2002.
- [9] Jaydeep Lakwal*, D. M. Deshpande, Arisutha Suresh, Arvind Mittal, " Cascaded Multilevel Inverter Topologies for Photovoltaic Power Generation Systems" International Journal of ChemTech Research CODEN (USA): IJCRGG, Vol.5, No.2, pp 1094-1100, April-June 2013.