



## Renewable and Nonrenewable Energy

Vol: 5(1), 2026

REST Publisher; ISBN: 978-81-948459-2-8

Website: <https://restpublisher.com/book-series/ese/>

DOI: <https://doi.org/10.46632/rne/5/1/3>

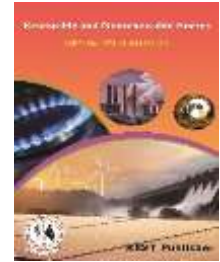

# Harmonics Reduction in Solar Inverters by Using Multilevel Scheme Having Level Modules and H-Bridge Inverter

\*K. Kalyani Radha, B. Omprakash

JNTUACEA, Ananthapuramu, Andhra Pradesh, India.

\*Corresponding Author Email: [radha.mech@jntua.ac.in](mailto:radha.mech@jntua.ac.in)

**Abstract:** This paper examines and estimates the similarities or dissimilarities of two methods for dc to ac power conversion. Cascaded H-Bridge Inverter is the first approach and new Multi-level Scheme which has H-Bridge and Level Modules. SIMULINK/MATLAB software is used to show the output voltage and current waveforms. Real power, reactive power and the total distortion of harmonics in resultant load voltage developed by the two methods are compared. It is indicated that THD developed in the new multi-level scheme is advantageous up to some stages of the first scheme. And the resultant real and reactive powers are effective for the latter scheme.

**Key Words:** Real power, Reactive power, Total Harmonic Distortion, H-Bridge Inverter circuit, Isolated or Grid connected load.

## 1. INTRODUCTION

The cost of fuels such as oil, gas, coal has been increasing also the availability of these fuels have been declining but the demand for electricity is growing thus to reach the demand for electricity there is a need to switch non-conventional energy sources such as geo-thermal, tidal, wave, solar etc. The energy obtained from solar system is in dc form. Most of the electrical appliances used in households and industries driven by ac power. The resultant power obtained from solar system is converted into ac and then given to an isolated load or grid connected system. Now a day's multilevel inverters are gaining popularity. Since the quality of power gets effectively better with the increasing levels in the resultant waveform

In this paper two methods are discussed for dc to ac conversion.

**Cascaded H-Bridge Inverter:** In the group of multilevel inverters cascaded multilevel inverter is one of the significant topologies. The cascaded topology admits the use of number of levels of dc voltages to produce expected ac voltage. H-Bridge inverter comprises of dc source which is fed from solar system, an isolated load or grid connected load across the two arm of H-Bridge inverter and four switches. Each switch in the inverter circuit triggers for  $180^\circ$ . The triggering pulses for two opposite corner switches are same.

A one stage H-Bridge inverter circuit is shown in the below Fig. 1. A cascaded multilevel Inverter circuit comprises of multiple H-Bridge inverter units with individual dc source in each unit and is connected in series as shown below Fig. 2.

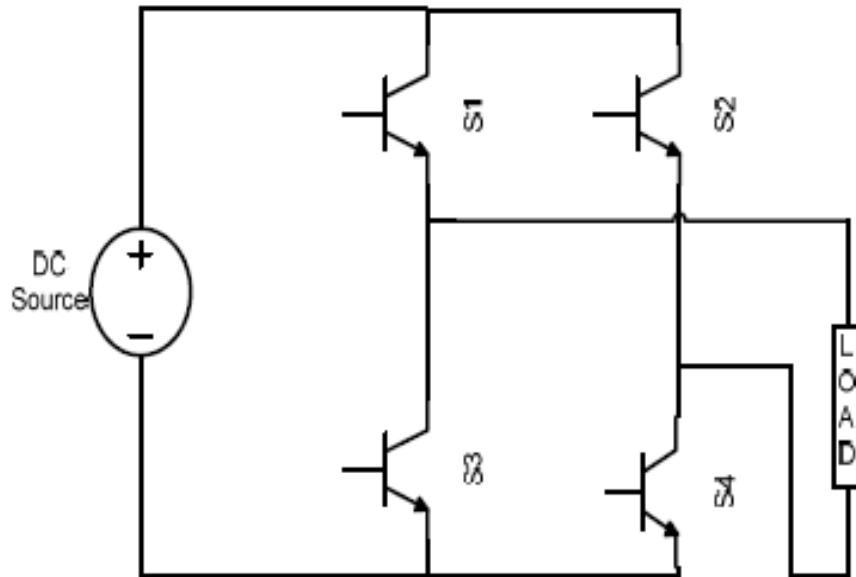

FIGURE 1. Single stage H-Bridge Inverter

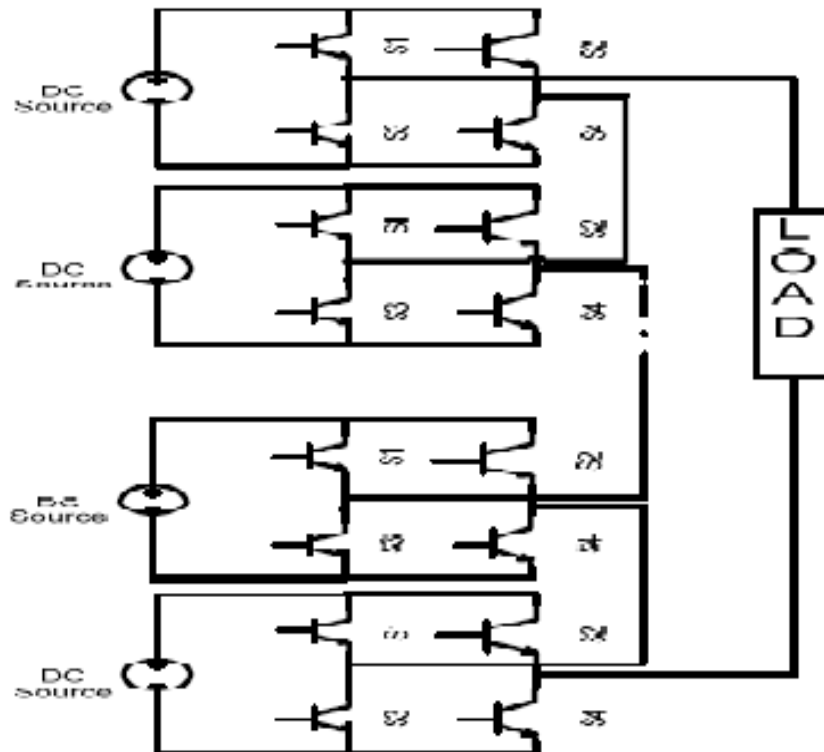

FIGURE 2. Cascaded Multilevel H-Bridge Inverter

The Total Harmonic Distortion, Real power, Imaginary power are determined for single stage and multi stage H-bridge Inverter. For the simulation SIMULINK/MATLAB software is used.

## 2. MATLAB CIRCUIT MODELS AND OUTPUT VOLTAGE WAVEFORMS OF DIFFERENT LEVELS

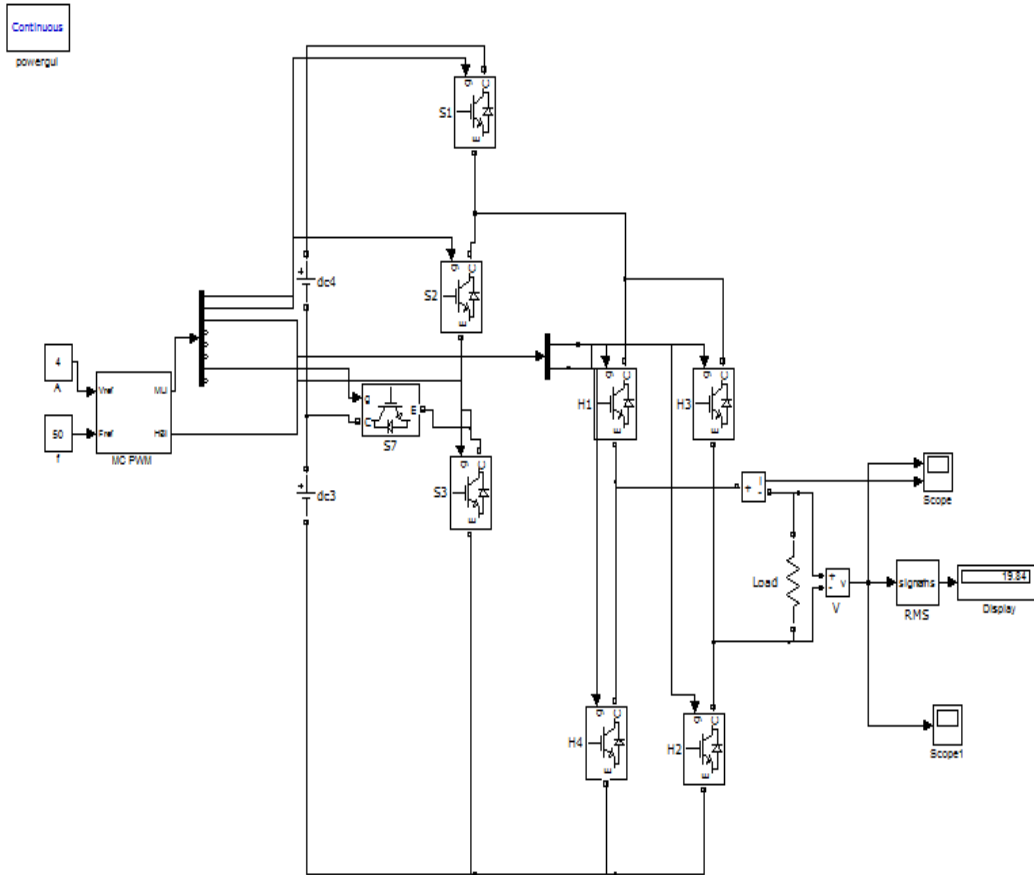

FIGURE 3. Five level Cascaded H-bridge inverter MATLAB model

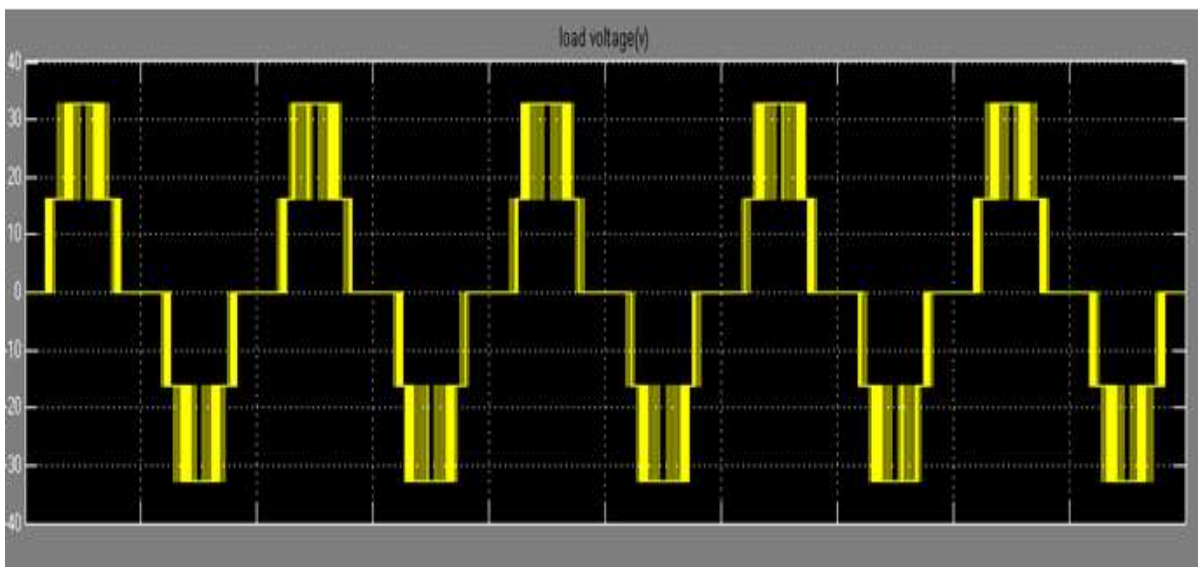

FIGURE 4. Output load voltage waveform of 5-level cascaded H-Bridge Inverter

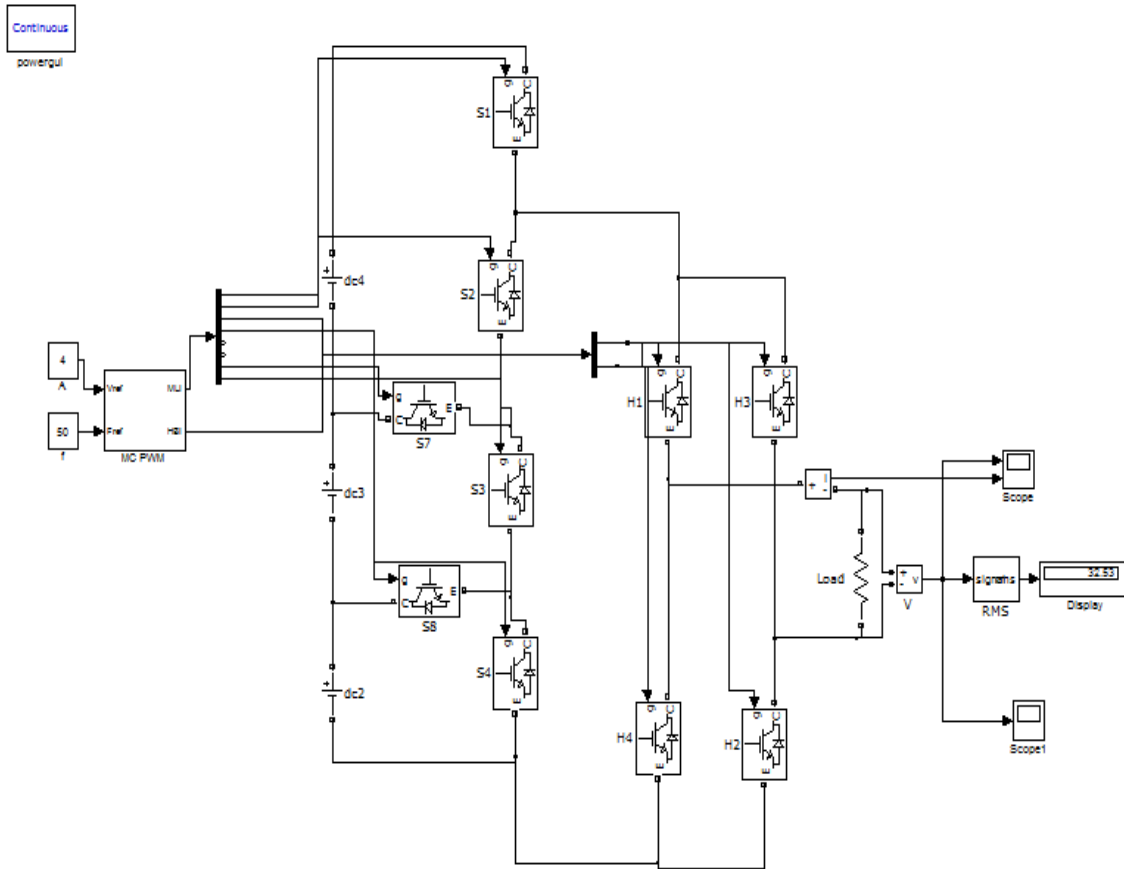

FIGURE 5. Seven level cascaded H-Bridge inverter MATLAB model.

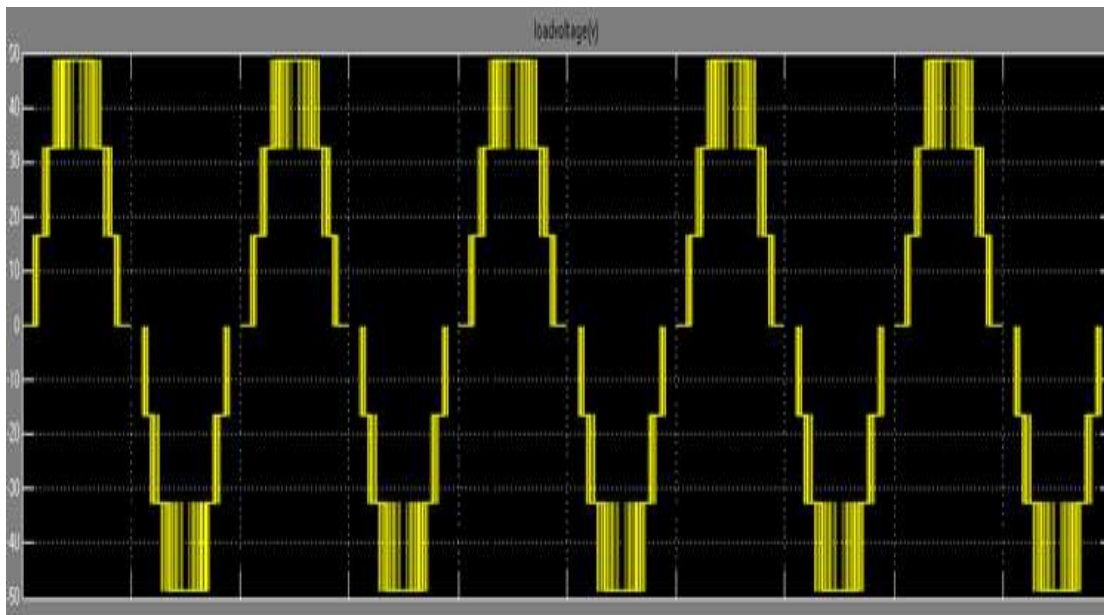

FIGURE 6. Output load voltage waveform of 7-level cascaded H-Bridge inverter

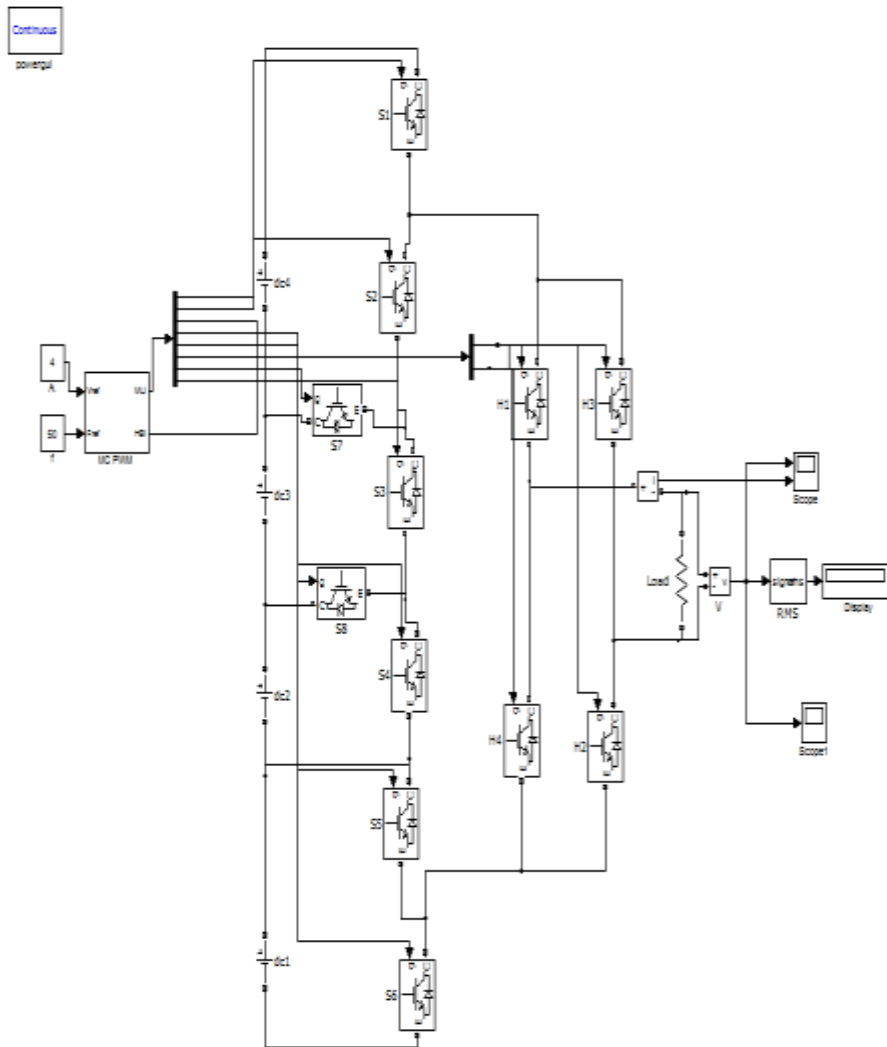

FIGURE 7. Nine level cascaded H-Bridge inverter MATLAB model

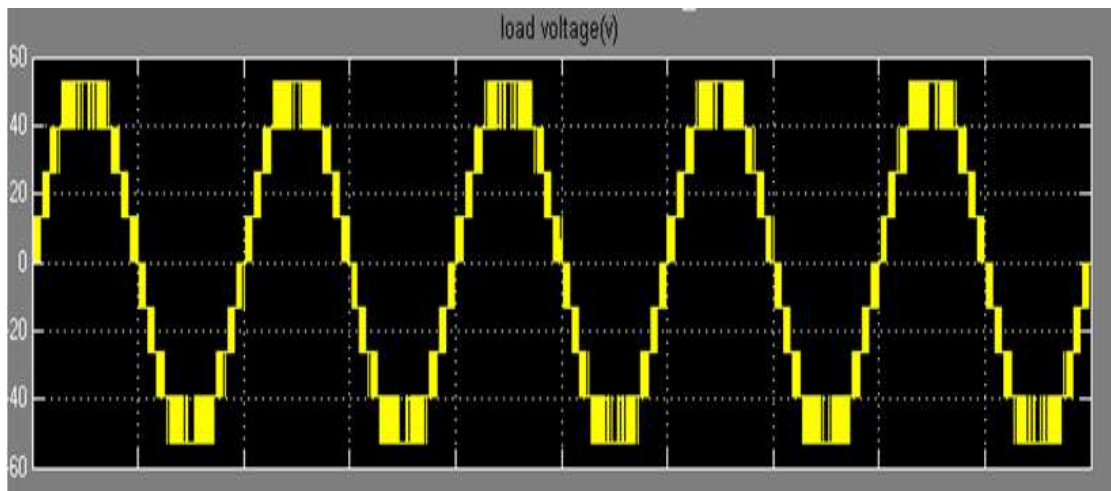

FIGURE 8. Output load voltage waveform of 9-level cascaded H-Bridge inverter

**New Multilevel Approach:** The new multilevel circuit comprises of level module, given dc voltage, H-Bridge inverter and Restive- Inductive load as shown in the below Fig. 9. The connected load may isolate or grid connected type. The level of resultant voltage shape depends on the level module used in the circuit.

Resultant Level

$$m=2(n+1)-1$$

Where n is the number of level module used.

The number of switches used in the circuit is given by

$$q=2n+4$$

The input dc voltage varies as:  $V_r=2(r-1)V_d$

Where  $r=1, 2, 3 \dots n$

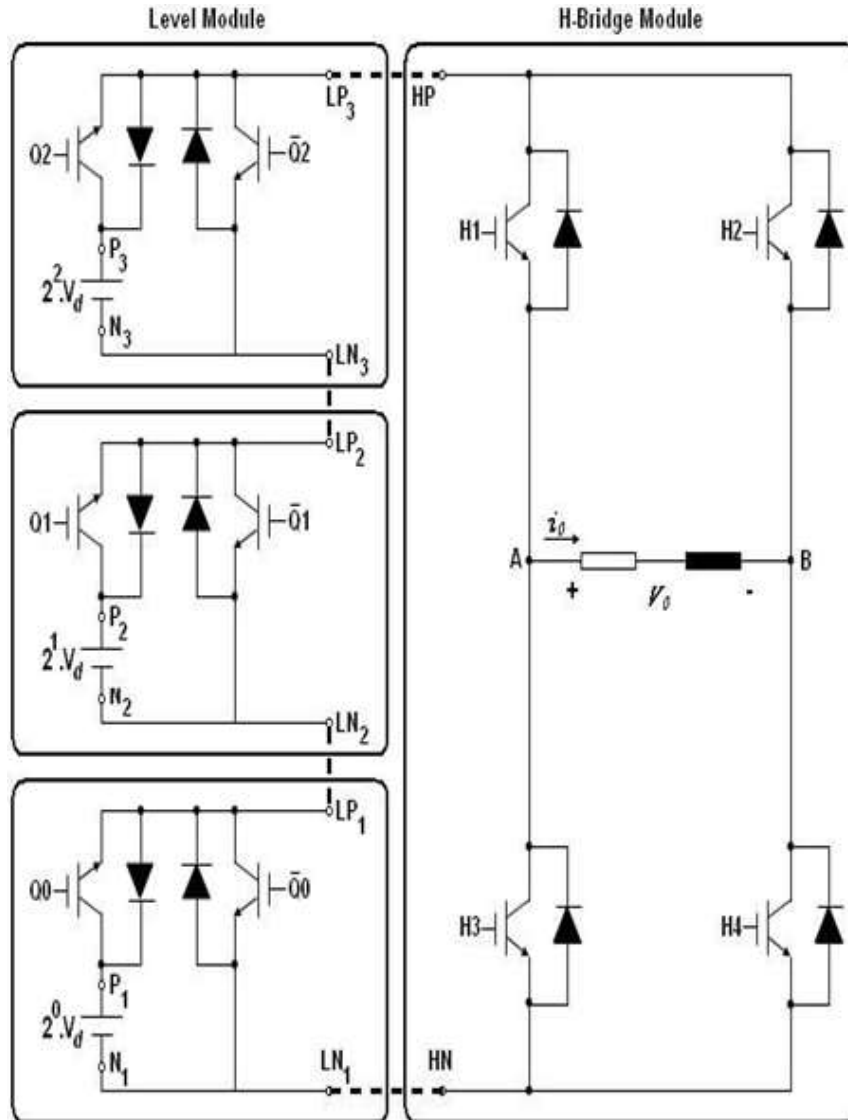

FIGURE 9. Proposed multilevel circuit

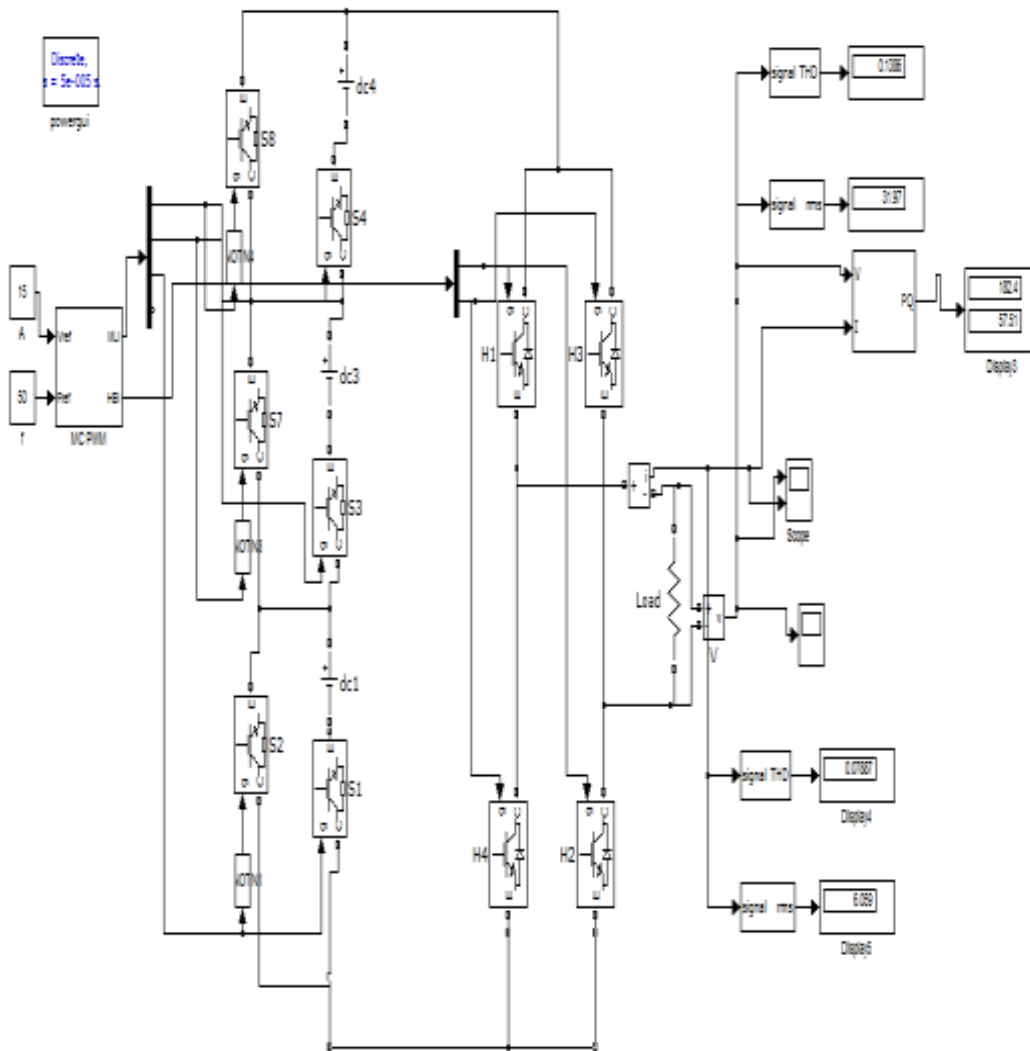

FIGURE 10. MATLAB model for the proposed circuit

In the proposed model circuit three level modules, one H-Bridge inverter and three dc voltage sources of  $V_d$ ,  $2V_d$  and  $4V_d$  are used. The resultant waveform has fifteen level and the number of switches used in the circuit are 10. The sum of the dc voltage in the circuit is given by sum of the individual dc voltages and is equal to  $7V_d$ .

The dc voltage  $V_d$  changes according to the variation of Total Harmonic Distortion, Real power and Reactive power for a constant load value of Resistance( $R$ )= $5\Omega$  and Inductance( $L$ )= $5\text{mH}$ . The MATLAB circuit model for the proposed circuit is shown in Fig. 10.

The 15-level resultant voltage waveform is shown in Fig. 11.

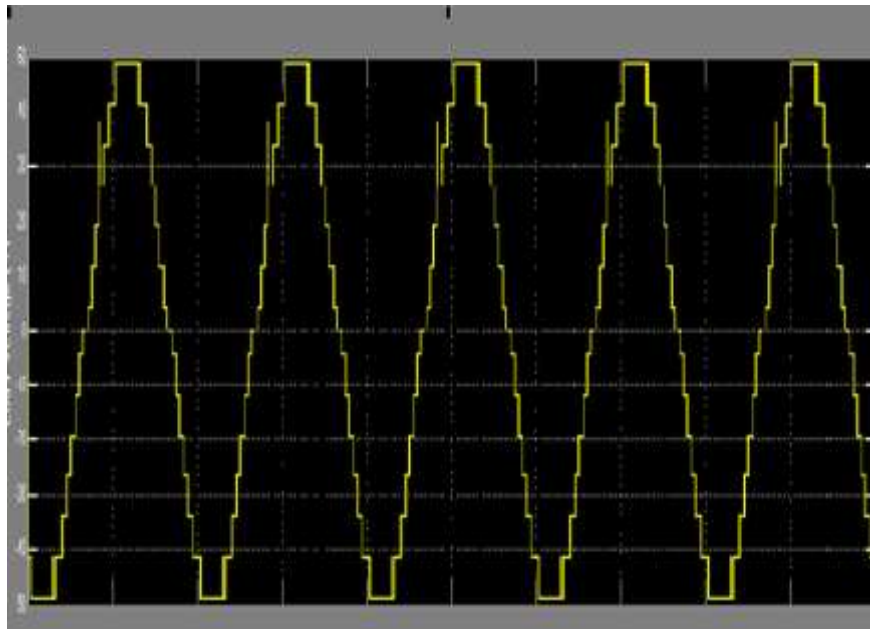

FIGURE 11. Output voltage waveform of proposed model

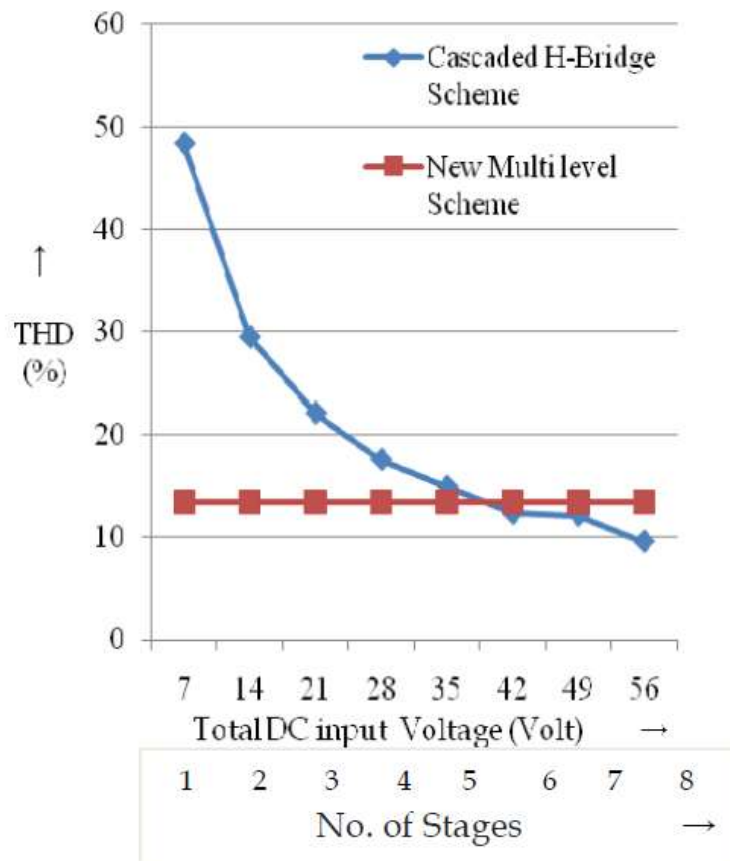

FIGURE 12. THD Vs DC input voltage (No. of stages) for Cascaded H-Bridge and New proposed multilevel scheme

### 3. COMPARISON

The Total Harmonic Distortion in the resultant voltage in the second scheme is less compared to Cascaded H-Bridge Inverter up to five stages. This implies that if the number of stages of the inverter in the first scheme is five or less, the Total Harmonic Distortion will be more that is the quality of power will be ineffective as compared to new multilevel scheme. Also the number of switches used and the resultant level in the Cascade H-Bridge having five stages are 20 and 6 respectively. Whereas the number of switches used and resultant level in new multilevel scheme are 10 and 15 respectively.

The change in Total Harmonic Distortion with the number of stages is shown in Fig. 12. For the case of one unit and up to Series connection of five units, the new multilevel scheme offers less Total Harmonic Distortion. If the stages number of stages are increased beyond five, the Total Harmonic Distortion will be effective for Cascaded scheme. In this paper the comparison between the two schemes is made without the use of filter. By using filters, the Total Harmonic Distortion can be further reduced in both the schemes. However, the cost of first scheme becomes large as compared to new multilevel scheme due to usage of a greater number of switches. Real power and Reactive power in the cascaded scheme are better for the same given dc voltage and same load, Real power and Reactive power increases with the total input dc voltage.

### 4. CONCLUSION

In this paper, total harmonic distortion in output load voltage, real power and imaginary power are obtained for the cascaded scheme and new multilevel scheme using simulink/matlab software and then for the same input dc voltage and resistive-inductive (rl) load without using filter. The total harmonic distortion is effective as well as the cost is less for new multilevel scheme. This means if the solar arrays with same power rating and same characteristic features are connected in the two schemes, the quality of power will be effective and the cost is less for the new multilevel scheme. Real power and imaginary power are better for the first scheme as compared to second scheme.

### REFERENCES

- [1]. Abu Tariq, Mohammed Aslam Husain, Mohammad Ahmad and Mohd. Tariq, "Simulation and study of a grid connected Multilevel Converter (MLC) with varying DC input", IEEE Conference on Environment and Electrical Energy International Conference EEEIC 2011, Italy, Rome, May 2011.
- [2]. J. Rodriguez, J.-S. Lai, and F. Z. Peng, "Multilevel inverters: A survey of topologies, controls and applications," IEEE Trans. Ind. Electron., Vol. 49.
- [3]. E. Kandemir Beser, B. Arifoglu, S. Camur and E Beser, "Design and Application of a Single-Phase Multilevel Inverter Suitable for using as a
- [4]. E. Beser, S. Camur, B. Arifoglu, E. Kandemir Beser, "Design and application of a novel structure and topology for multilevel inverter," 2008.
- [5]. Jagdish Kumar, Biswarup Das and Pramod Agarwal, "Harmonic Reduction Technique for a Cascade Multilevel Inverter", International.
- [6]. E. Beser, S. Camur, B. Arifoglu, E. Kandemir Beser, "A grid connected photovoltaic power conversion system with single phase multilevel inverter," Solar Energy 84 (2010), pp. 2056-2067.
- [7]. G. Mahesh, Manivanna Kumar and S. Rama Reddy, "Simulation and Experimental Results of 7-Level Inverter System", Research Journal of Applied Sciences, Engineering and Technology, pp. 88-95, 2011