



## Renewable and Nonrenewable Energy

Vol: 5(1), 2026

REST Publisher; ISBN: 978-81-948459-2-8

Website: <https://restpublisher.com/book-series/ese/>

DOI: <https://doi.org/10.46632/rne/5/1/15>

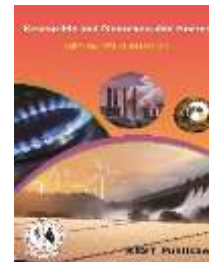

# Power Management Strategies for a Grid Connected PV-FC Hybrid System

\*K Kalyani Radha, B Omprakash

JNTUACEA, Ananthapuramu, Andhra Pradesh, India.

\*Corresponding Author Email: [radha.mech@jntua.ac.in](mailto:radha.mech@jntua.ac.in)

**Abstract:** This paper presents a method to operate a grid connected hybrid system. The hybrid system composed of a Photovoltaic (PV) array and a Proton exchange membrane fuel cell (PEMFC) is considered. The PV array normally uses a maximum power point tracking (MPPT) technique to continuously deliver the highest power to the load when variations in irradiation and temperature occur, which make it become an uncontrollable source. In coordination with PEMFC, the hybrid system output power becomes controllable. Two operation modes, the unit-power control (UPC) mode and the feeder-flow control (FFC) mode, can be applied to the hybrid system. The coordination of two control modes, the coordination of the PV array and the PEMFC in the hybrid system, and the determination of reference parameters are presented. The proposed operating strategy with a flexible operation mode change always operates the PV array at maximum output power and the PEMFC in its high efficiency performance band, thus improving the performance of system operation, enhancing system stability, and decreasing the number of operating mode changes.

**Keywords:** Distributed generation, fuel cell, hybrid system, micro grid, photovoltaic, power management.

## 1. INTRODUCTION

Renewable energy is currently widely used. One of these resources is solar energy. The photovoltaic array normally uses a maximum power point tracking technique to continuously deliver the highest power to the load when there are variations in irradiation and temperature. The disadvantage of PV energy is that the PV output power depends on weather conditions and cell temperature, making it an uncontrollable source. Furthermore, it is not available during the night. In order to overcome these inherent drawbacks, alternative sources, such as PEMFC, should be installed in the hybrid system. By changing the FC output power, the hybrid source output becomes controllable. However, PEMFC, in its turn, works only at a high efficiency within a specific power range. The hybrid system can either be connected to the main grid or work autonomously with respect to the grid-connected mode or islanded mode, respectively. In the grid-connected mode, the hybrid source is connected to the main grid at the point of common coupling (PCC) to deliver power to the load. When load demand changes, the power supplied by the main grid and hybrid system must be properly changed. The power delivered from the main grid and PV array as well as PEMFC must be coordinated to meet load demand. The hybrid source has two control modes: 1) unit-power control (UPC) mode and 2) feeder-flow control (FFC) mode. Fig.1 shows the interconnection of the hybrid system.

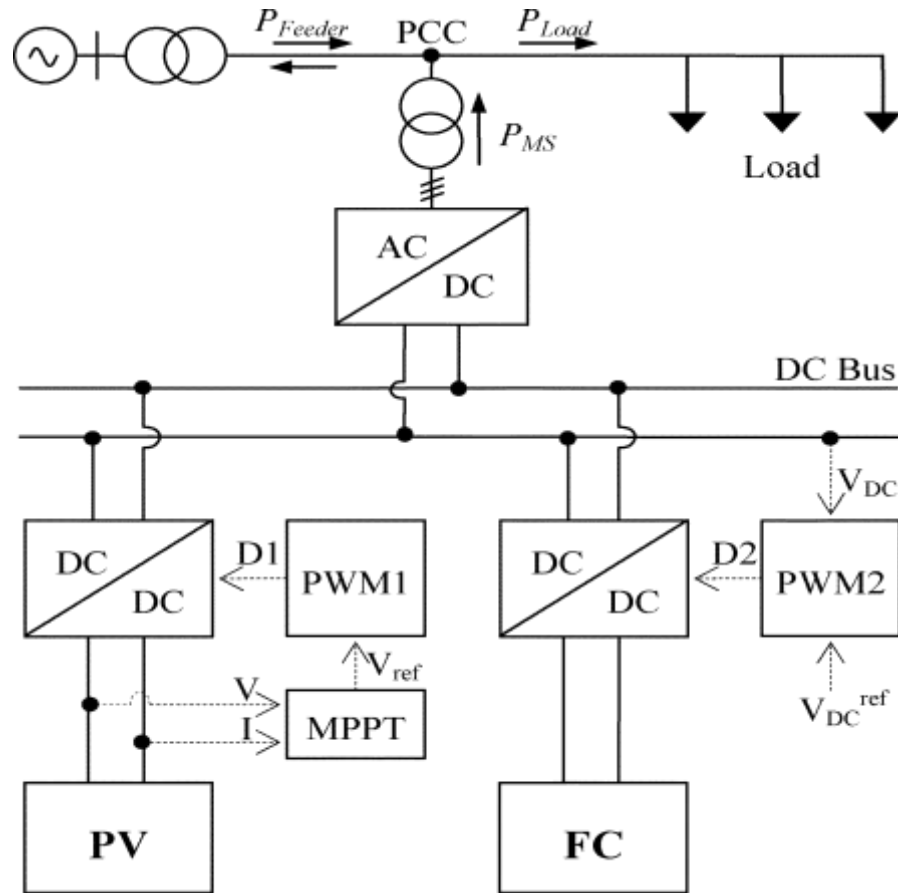

FIGURE 1. Grid-connected PV-FC hybrid system

## 2. LITERATURE SURVEY

F. Katiraei and M. R. Iravani, proposed a paper on Power management strategies for a micro grid with multiple distributed generation units from this I can extract the real and reactive power management strategies of electronically interfaced distributed generation (DG) units in the context of a multiple-DG micro grid system. The emphasis is primarily on electronically interfaced DG (EI-DG) units.

J.Larmine and A.Dicks, proposed a paper on Fuel Cell Systems and its operation used for power generation. From this power generation using hydrogen is analyzed.

T.Bocklisch, W.Schufft, and S.Bocklisch, proposed a paper on Predictive and optimizing energy management of photovoltaic fuel cell hybrid systems with short time energystorage.

## 3. SYSTEM DESCRIPTION

*Structure of Grid-Connected Hybrid Power System:* The system consists of a PV-FC hybrid source with the main grid connecting to loads at the PCC as shown in Fig. 1. The photovoltaic and the PEMFC are modeled as nonlinear voltage sources. These sources are connected to dc-dc converters which are coupled at the dc side of a dc/ac inverter. The dc/dc connected to the PV array works as an MPPT controller. Many MPPT algorithms have been proposed in the literature, such as incremental conductance (INC), constant voltage (CV), and perturbation and observation (P&O). The P&O method has been widely used because of its simple feedback structure and fewer measured parameters. The P&O algorithm with power feedback control is shown in Fig. 2. As PV voltage and current are determined, the power is calculated. At the maximum power point, the

derivatives  $dP/dV$  is equal to zero. The maximum power point can be achieved by changing the reference voltage by the amount of  $\Delta V_{ref}$ .

**A. PV array model**

The mathematical model can be expressed as

$$I = I_{ph} - I_{sat} \left\{ \exp \left[ \frac{q}{k_B T} (V + IR_s) \right] - 1 \right\} \quad (1)$$

Equation (1) shows that the output characteristic of a solar cell is nonlinear and vitally affected by solar radiation, temperature, and load condition. Photocurrent  $I_{ph}$  is directly proportional to solar radiation  $G_a$ .

$$I_{ph}(G_a) = I_{sc} \frac{G_a}{G_{as}} \quad (2)$$

The short-circuit current of solar cell  $I_{sc}$  depends linearly on cell temperature.

$$I_{sc}(T) = I_{scs} [1 + \Delta I_{sc} (T - T_s)] \quad (3)$$

Thus,  $I_{ph}$  depends on solar irradiance and cell temperature  $I_{sat}$  also depends on solar irradiation and cell temperature and can be mathematically expressed as follows.

$$I_{ph}(G_a, T) = I_{scs} \frac{G_a}{G_{as}} (1 + \Delta I_{sc} (T - T_s)) \quad (4)$$

$I_{sat}$  Also depends on solar irradiation and cell temperature and can be mathematically expressed as follows:

$$I_{sat}(G_a, T) = \frac{I_{ph}(G_a, T)}{e^{\left(\frac{V_{oc}(T)}{V_T(T)}\right)} - 1} \quad (5)$$

**B. PEMFC Model:**

The PEMFC steady-state feature of a PEMFC source is assessed by means of a polarization curve, which shows the non-linear relationship between the voltage and current density. The PEMFC output voltage is as follows [5]:

$$V_{out} = E_{Nerst} - V_{act} - V_{ohm} - V_{conc} \quad (6)$$

Where  $E_{Nerst}$  is the “thermodynamic potential” of Nerst, which represents the reversible (or open-circuit) voltage of the fuel cell. Activation voltage drop  $V_{act}$  is given in the Tafel equation as

$$V_{act} = T[a + b \ln(I)] \quad (7)$$

Where  $a$  and  $b$  are the constant terms in the Tafel equation (involts per Kelvin). The overall ohmic voltage drop  $V_{ohm}$  can be expressed as

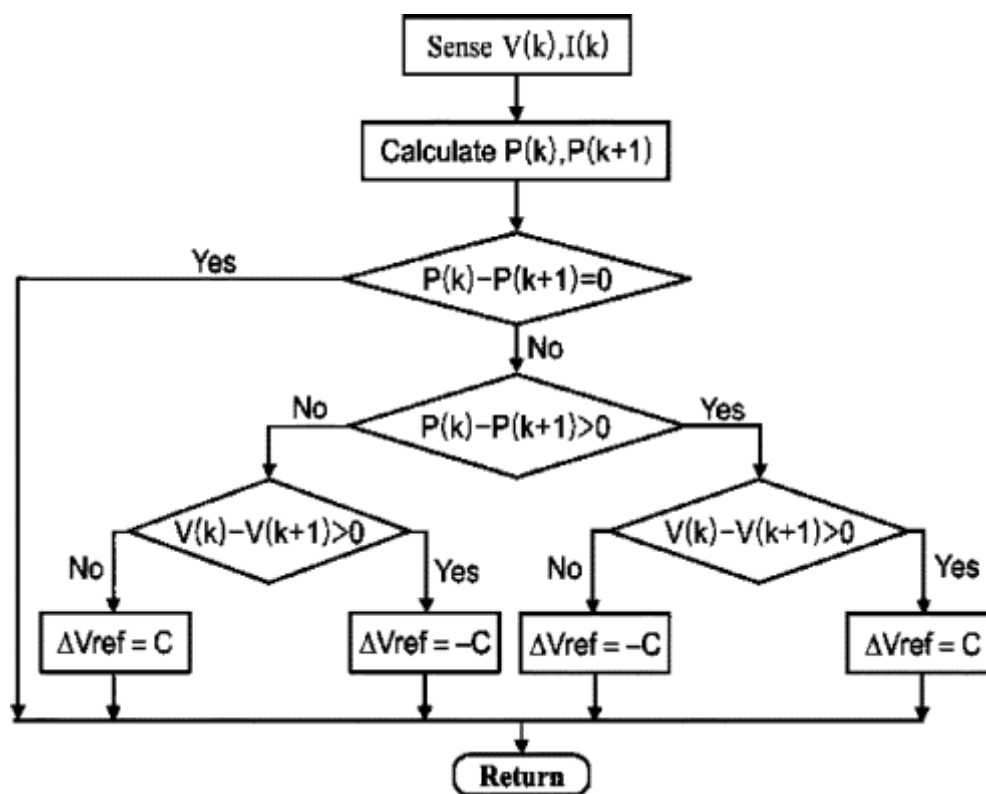

FIGURE 2. P&amp;O MPPT algorithm.

The overall ohmic voltage drop  $V_{ohm}$  can be expressed as

$$V_{ohm} = I R_{ohm} \quad (8)$$

The ohmic resistance  $R_{ohm}$  of PEMFC consists of the resistance of the polymer membrane and electrodes, and the resistances of the electrodes. The concentration voltage drop  $V_{conc}$  is expressed as

$$V_{conc} = -\frac{RT}{ZF} \ln \left( 1 - \frac{I}{I_{limit}} \right) \quad (9)$$

### C. MPPT Control:

Many MPPT algorithms have been proposed in the literature, such as incremental conductance (INC), constant voltage (CV), and perturbation and observation (P&O). The two algorithms often used to achieve maximum power point tracking are the P&O and INC methods. The INC method offers good performance under rapidly changing atmospheric conditions. However, four sensors are required to perform the computations. If the sensors require more conversion time, then the MPPT process will take longer to track the maximum power point. During tracking time, the PV output is less than its maximum power. This means that the longer the conversion time is, the larger amount of power loss [7] will be. On the contrary, if the execution speed of the P&O method increases, then the system loss will decrease. Moreover, this method only requires two sensors, which results in a reduction of hardware requirements and cost. Therefore, the P&O method is used to control the MPPT process.

In order to achieve maximum power, two different applied control methods that are often chosen are voltage-feedback control and power-feedback control [8], [9]. Voltage-feedback control uses the solar-array terminal voltage to control and keep the array operating near its maximum power point by regulating the array's voltage and matching the voltage of the array to a desired voltage. The drawback of the voltage-feedback control is its neglect of the effect of irradiation and cell temperature.

Therefore, the power-feedback control is used to achieve maximum power. The P&O MPPT algorithm with a power-feedback control [9],[10] is shown in Fig.2. As PV voltage and current are determined, the power is calculated. At the maximum power point, the derivative  $dP/dV$  is equal to zero. The maximum power point can be achieved by changing the reference voltage by the amount of  $\Delta V_{ref}$ . In order to implement the MPPT algorithm, a buck-boost dc/dc converter is used as depicted in Fig.3. The parameters  $L$  and  $C$  in the buck-boost converter must satisfy the following conditions.

$$L > \frac{(1-D)^2 R}{2f} ; C > \frac{D}{Rf \left(\frac{\Delta V}{V_{out}}\right)} \quad (10)$$

The buck-boost converter consists of one switching device (GTO) that enables it to turn on and off depending on the applied gate signal. The gate signal for the GTO can be obtained by comparing the saw tooth wave form with the control voltage [7]. The change of the reference voltage  $\Delta V_{ref}$  obtained by MPPT algorithm becomes the input of the pulse width modulation (PWM). The PWM generates a gate signal to control the buck-boost converter and, thus, maximum power is tracked and delivered to the ac side via a dc/ac inverter.

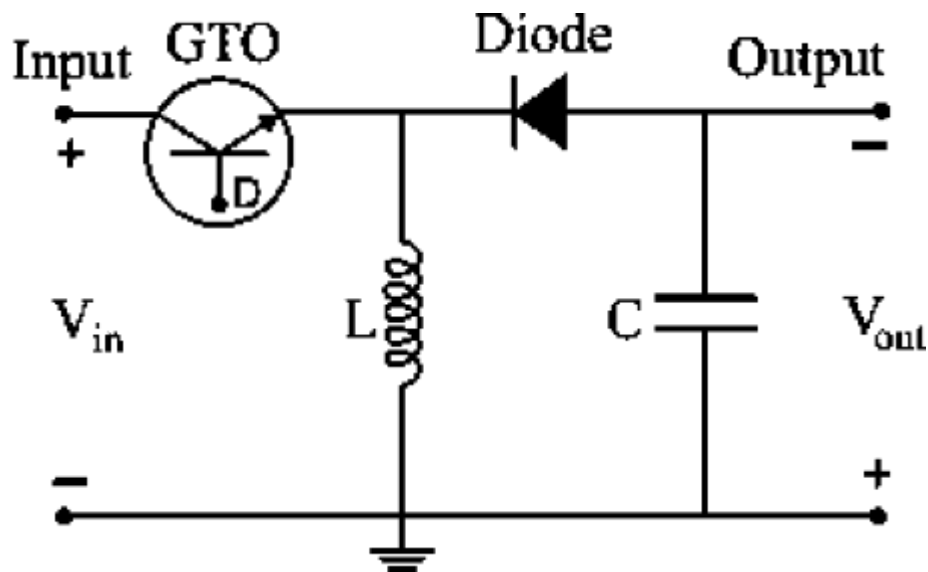

FIGURE 3. Buck-boost topology.

#### 4. CONTROL OF THE POWER SYSTEM

The control modes in the micro grid include unit power control, feeder flow control, and mixed control mode. The two control modes were first proposed by Lasseter. In the UPC mode, the DGs (the hybrid source in this system) regulate the voltage magnitude at the connection point and the power that source is injecting. In this mode if a load increases anywhere in the micro grid, the extra power comes from the grid, since the hybrid source regulates to a constant power. In the FFC mode, the DGs regulate the voltage magnitude at the connection point and the power that is flowing in the feeder at connection point P feeder. With this control mode, extra load demands are picked up by the DGs, which maintain a constant load from the utility view point. In the mixed control mode, the same DG could control either its output power or the feeder flow power. In other words, the mixed control mode is a coordination of the UPC mode and the FFC mode. In this paper, a coordination of the UPC mode and the FFC mode was investigated to determine when each of the two control modes was applied and to determine a reference value for each mode. Moreover, in the hybrid system, the PV and PEMFC sources have their constraints. Therefore, the reference power must be set at an appropriate value so that the constraints of these sources are satisfied. The proposed operation strategy presented in the next section is also based on the minimization of mode change. This proposed operating strategy will be able to improve performance of the system operation and enhance system stability.

### 5. CONTROL OF HYBRID SYSTEM

As mentioned before, the purpose of the operating algorithm is to determine the control mode of the hybrid source and the reference value for each control mode so that the PV is able to work at maximum output power and the constraints are fulfilled. Once the constraints ( $P_{FC}^{up}$ ,  $P_{FC}^{low}$ ,  $P_{FC}^{max}$ ) on load variations and the PV output.. The control mode is decided by the algorithm shown in Fig.4

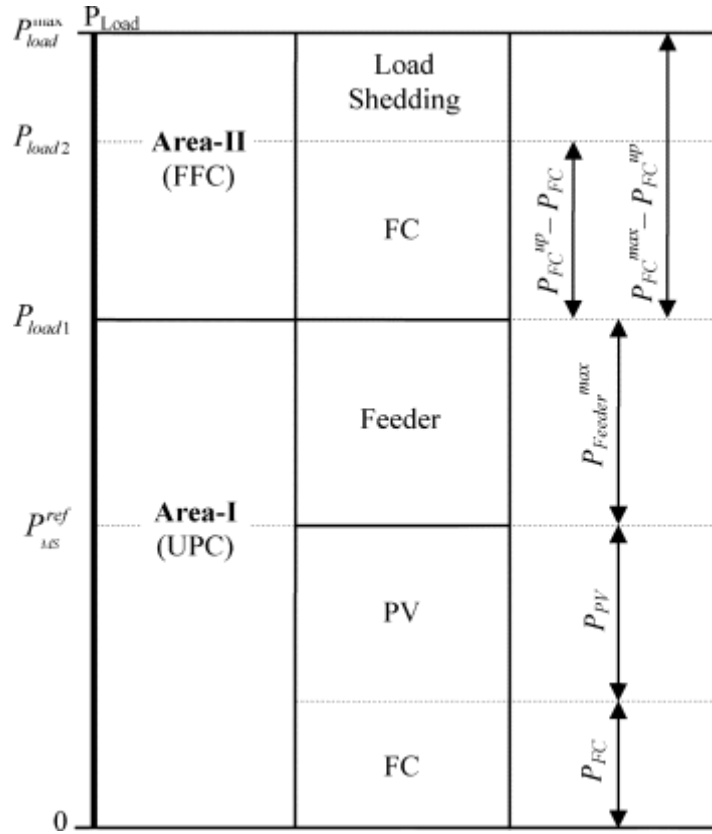

FIGURE 4. Overall operating strategy for the grid-connected hybrid system

### 6. SIMULATION RESULTS

A simulation was carried out by using the system model shown in Fig. 2 to verify the operating strategies. In order to verify the operating strategy, the load demand and PV output were time varied in terms of step. According to the load demand and the change of PV output and the operating mode were determined by the proposed operating algorithm. The following outputs are described: the unit power flow control mode of operation, feeder flow control mode of operation and mixed operation of the hybrid system shown in the figure

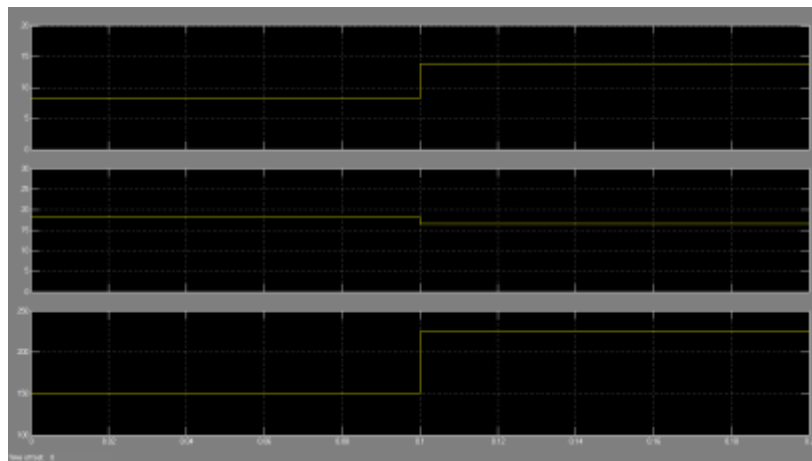
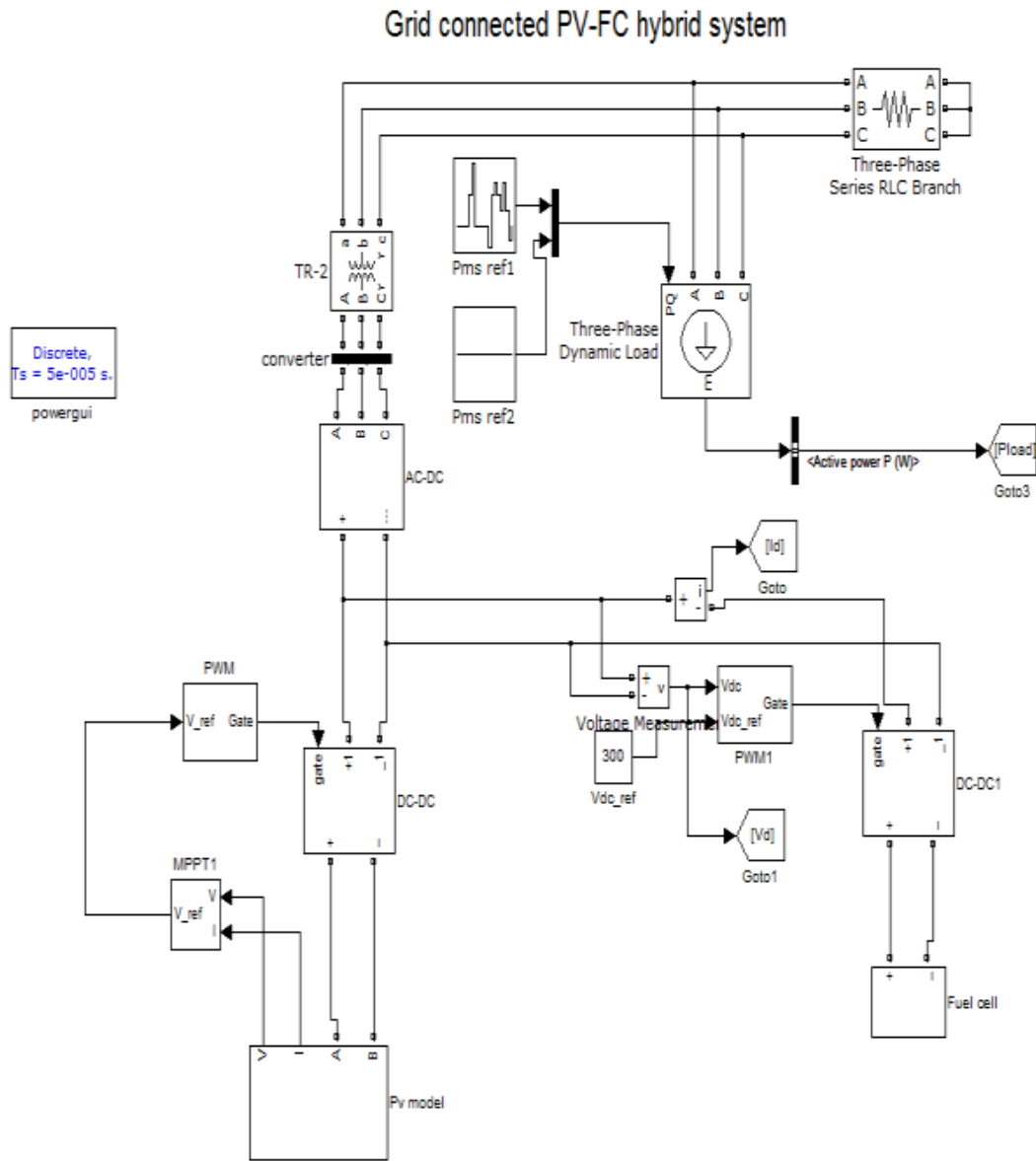

Figure 5. operating strategies of hybrid system

## 7. CONCLUSION

This paper has presented an available method to operate a hybrid grid-connected system. The hybrid system, composed of a PV array and PEMFC, was considered. The operating strategy of the system is based on the UPC mode and FFC mode. The purposes of the proposed operating strategy presented in this paper are to determine the control mode, to minimize the number of mode changes, to operate PV at the maximum power point, and to operate the FC output in its high-efficiency performance band. The system works flexibly, exploiting maximum solar energy; PEMFC works with in a high-efficiency band and, hence, improves the performance of the system's operation. The system can maximize the generated power when load is heavy and minimizes the load shedding area. When load is light, the UPC mode is selected and, thus, the hybrid source works more stably.

## REFERENCES

- [1]. J. Larminie and A. Dicks, Fuel Cell Systems Explained. New York:Wiley,2011.
- [2]. W. Xiao, W. Dunford, and A. Capel, "A novel modeling method for photovoltaic cells," in *Proc. IEEE 35th Annu. Power Electronics Specialists Conf., Jun. 2009*
- [3]. D. Sera, R. Teodorescu, and P. Rodriguez, "PV panel model based on data sheet values," in *Proc. IEEE Int. Symp. Industrial Electronics, Jun. 4-7, 2007, pp. 2392-2396*.
- [4]. C. Wang, M. H. Nehrir, and S. R. Shaw, "Dynamic models and model validation for PEM fuel cells using electrical circuits," *IEEE Trans. Energy Convers., vol. 20, no. 2, pp. 442-451, Jun. 2005*.
- [5]. C. Hua and C. Shen, "Comparative study of peak power tracking techniques for solar storage system," in *Proc. 13th Annu. Applied Power Electronics Conf. Expo., Feb. 2004, vol. 2, pp. 679-685*.
- [6]. A. Hajizadeh and M. A. Golkar, "Power flow control of grid-connected fuel cell distributed generation systems," *J. Elect. Eng. Technol., vol. 3, no. 2, pp. 143-151, 2008*.
- [7]. C. Hua and J. R. Lin, "DSP-based controller application in battery storage of photovoltaic system," in *Proc. 22nd IEEE Int. Conf. Industrial Electronics, Control, and Instrumentation, Aug. 5-10, 2002, vol. 3, pp. 1750-1810*.
- [8]. C. Hua, J. Lin, and C. Shen, "Implementation of a DSP-controlled photovoltaic system with peak power tracking," *IEEE Trans. Ind. Electron., vol. 45, no. 1, pp. 99-107, Feb. 2000*.