



## Renewable and Nonrenewable Energy

Vol: 5(2), 2026

REST Publisher; ISBN: 978-81-948459-2-8

Website: <https://restpublisher.com/book-series/ese/>

DOI: <https://doi.org/10.46632/rne/5/2/11>

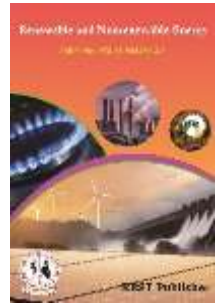

# Structural Static and Dynamic Evaluation of 1 KW Small Wind Turbine Blades Using Different Materials

\*K Kalyani Radha, B Omprakash

JNTUACEA, Ananthapuramu, Andhra Pradesh, India.

\*Corresponding Author Email: [radha.mech@jntua.ac.in](mailto:radha.mech@jntua.ac.in)

**Abstract:** Due to the increasing environmental and economic cost of fossil fuels, alternative sources of energy are needed. One such a source is wind energy. The main objective of the project includes Modeling and analysis of small wind turbine blades by using a standard NACA air foil. In the present work, an attempt is made to evaluate the performance of small wind turbine blade models, through FEA. Static analysis and Dynamic analysis is performed on blade models, and post processed results are analysed. Modeling of wind turbine blades done by using Pro/Engineer software, material used are E-glass epoxy and S-glass epoxy. NACA air foil 63012A blade profile generated. The Blades are twisted to 15<sup>0</sup> and 30<sup>0</sup> angles. Analysis is processed on two different wind turbine blade materials with twisted angles. Comparison is done for the two different wind turbine blade materials with twisted angles and concludes the better blade model. Modeling is done using Pro/Engineer software and Analysis is done using ANSYS.

**Keywords:** NACA air foils 63012A, E-glass epoxy and S-glass epoxy.

## 1. INTRODUCTION

In these modern days the population is rapidly increasing and consumption of power in various fields also increased. Hence, it is very essential to find for an alternative power generation techniques on which all the aspects of modern day technology mainly depends. In that we have non-conventional power generation techniques such as solar power, wind power, tidal power which are eco-friendly, abundantly available in nature. Renewable energy has gained importance in the background of the debates and discussions on climate change all over the world. Resources are gaining importance in reducing global warming gas emissions as they do not depend on fossil fuel. In India at present more than 75% of the power generation depends on coal based thermal power plants. In the background of emerging global obligations to bring down emissions of gases responsible for global warming the Government of India has brought out promising legal provisions and policies to promote renewable energy. Here it will not be out of place to mention that India is the first country to have a separate ministry – Ministry for New and Renewable Energy (MNRE) – to promote renewable energy based power generation in the country. The utilization of wind energy for power generation purposes is becoming increasingly attractive and gaining a great share in the electrical power production market world-wide. A Wind Turbine is a device that converts kinetic energy from the wind, also called wind energy, into mechanical energy a process known as wind power. If the mechanical energy is used to produce electricity, the device may be called a Wind turbine or Wind power plant. If the mechanical energy is used to drive machinery, such as for grinding grain or pumping water, the device is called a wind mill or wind pump. Similarly, it may refer to as a Wind charger when used for charging batteries. The modern wind turbine is a system that comprises three integral components with distinct disciplines of engineering science. The rotor component includes the blades for converting wind energy to an intermediate low speed rotational energy. The generator component includes the electrical generator, the control electronics, and most likely a gearbox component for converting the low speed rotational energy to electricity. The structural support component includes the tower for optimally situating the rotor component to the wind energy source. The result

of over a millennium of windmill development and modern engineering, today's wind turbines are manufactured in a wide range of vertical and horizontal axis types.

## 2. LITERATURE REVIEW

**T.Vishnuvardhan, Dr.B.Durga Prasad [1]** was proposed their paper presenting the development of small wind turbine blade models in two different profiles R21 and R22. NACA 63-415 airfoil is used for the development of blades. The blades are developed and fabricated for one kW wind turbine generator system. Finite element analysis conducted by varying the composition of materials used for blade fabrication. Experimental investigations through load deflection test and cyclic load bench test conducted on six blade varieties. The results show the degradation of material properties as the experiment is getting progressed. Finally a better performing blade was identified from the result obtained from FEA, load deflection test and cyclic load bench test.

**H.Ghasemnejad, A.Maheri [2]** describes the effect of delamination position on the critical buckling load and buckling mode of hybrid FRP composites applied in wind turbine blades is investigated. Experimental and numerical studies are carried out to determine the buckling load of delaminated composite beams. They have conducted as experiment with various laminate designs of delamination composite beams which are manufacture to test under critical buckling load by placing at different positions. From the experiments results it was that delamination position and lay-up can affect the buckling mode and also the critical buckling load. By approaching the delamination position to the outer surface of the specimen the buckling load decreases.

**Kevin Cox, Andreas Echtermeyer [3]** has designed the 70 meter long blade in an upwind, horizontal-axis wind turbine were developed in the paper for use in a high wind speed location. A hybrid composite structure was made using glass and carbon fiber plies to create yielding a light-weight design with a low tip deflection. The blade was subjected to FEA studies to demonstrate its ability to withstand the extreme loading conditions as defined in the international offshore wind standard. Further that the results confirmed the design to have sufficient performance with regard to tip deflection, maximum and minimum strains, and critical buckling load. Detailed descriptions of the structural components and ply lay ups are presented along with the resulting maximum and minimum strains and deflections. In addition, optimization techniques were introduced to provide insight for future studies with the blade.

## 3. MODELING OF WIND TURBINE BLADE

In this section the modeling of optimizes blade design is done in Pro/E modeling software. The blade is twisted at an angle of  $15^{\circ}$ .

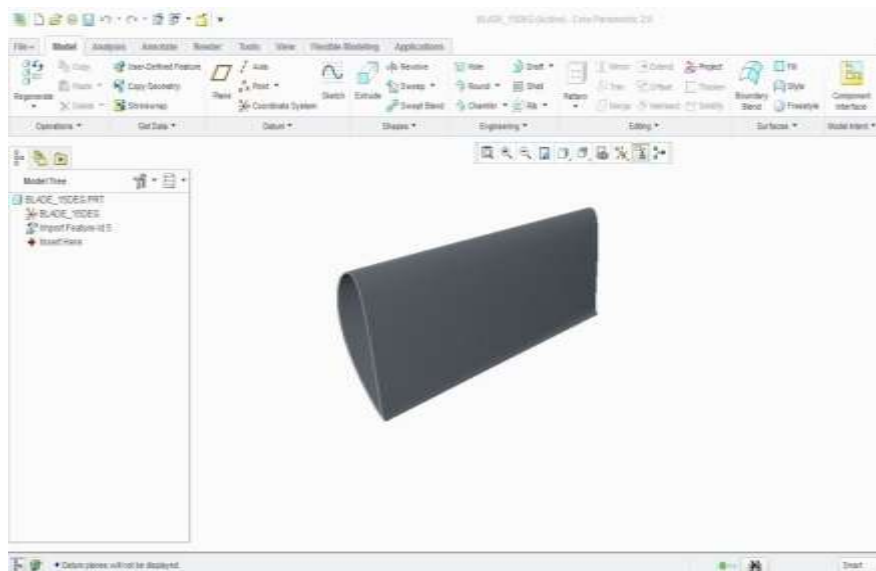

**FIGURE 1.** Modeling of Wind Turbine Blade of  $15^{\circ}$  angle

The blade is twisted at an angle of  $30^{\circ}$ .

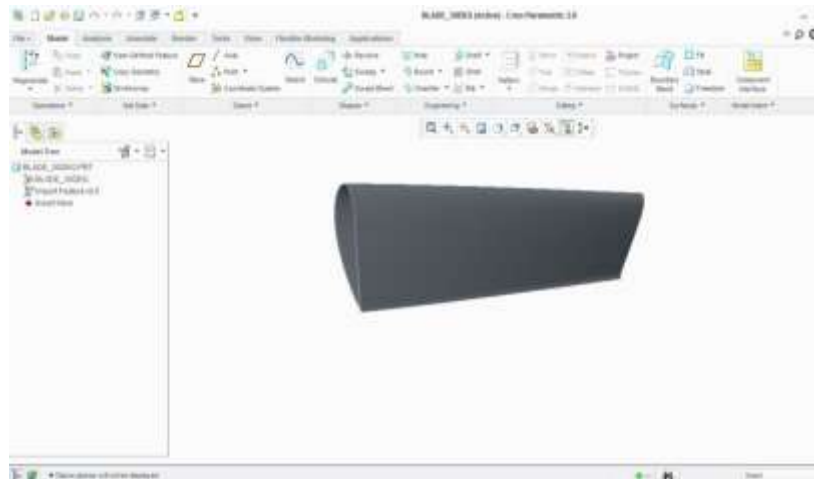

**FIGURE 2.** Modelling of Wind Turbine Blade of  $30^{\circ}$  angle

**TABLE 1.** Properties of Composite Materials

	E-glass	S-glass
Elastic Modulus	$7.24e+010N/m^2$	$8.69e+010N/m^2$
Poisson Ratio	0.2	0.22
Density	$2600kg/m^3$	$2490kg/m^3$
Yield Strength	490Mpa	593Mpa

**ANALYSIS**

**A. Static Analysis**

A structural model which created can be used to predict the behaviour of their modal structure, under the action of external forces. The response is usually measured in terms of deflection and stress. The response is static if the loads are steady. This analysis is called static analysis. A static analysis can be either linear or non-linear.

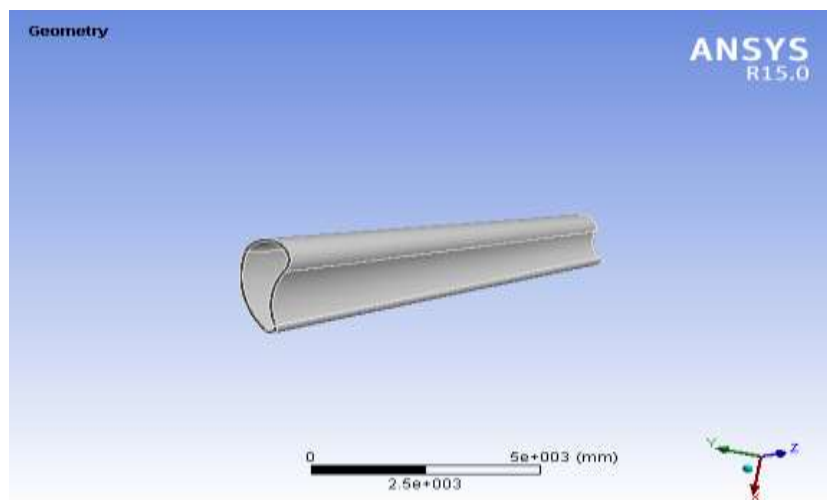

**FIGURE 3.** Importing Model of Wind Turbine Blade

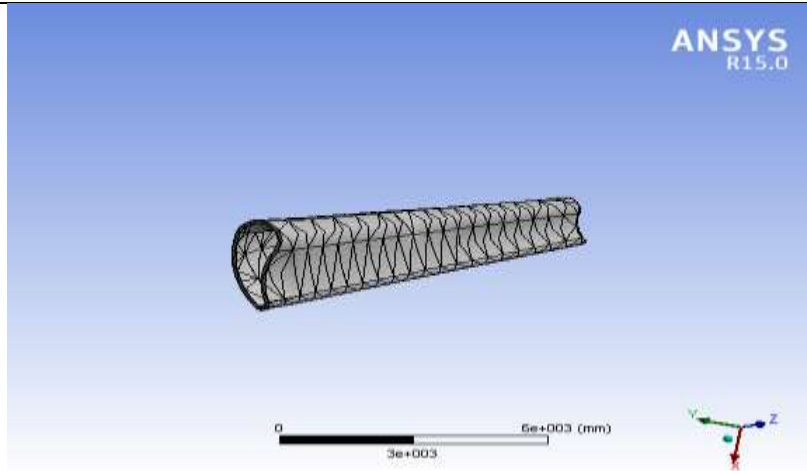

FIGURE 4. Meshing Model of Wind Turbine Blade

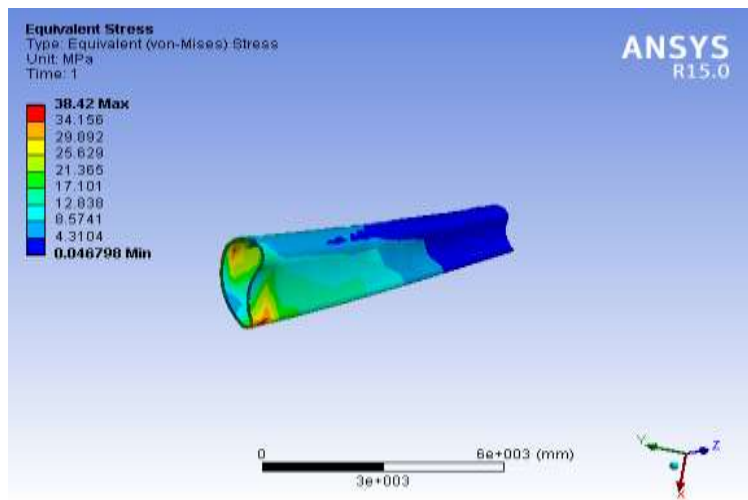
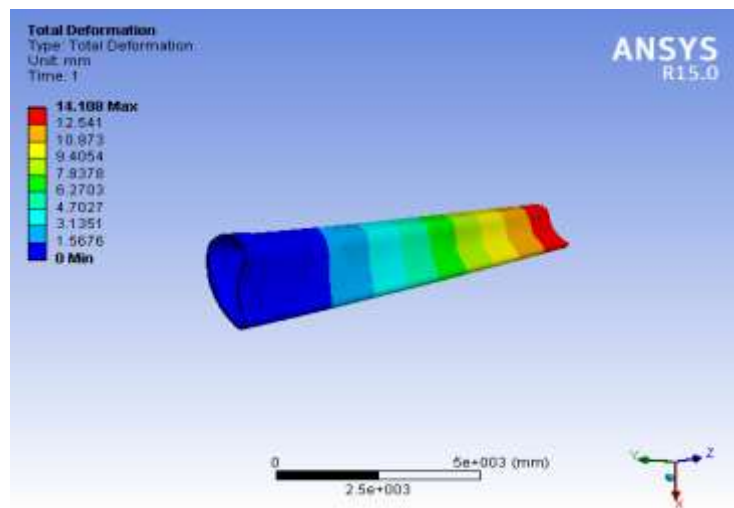
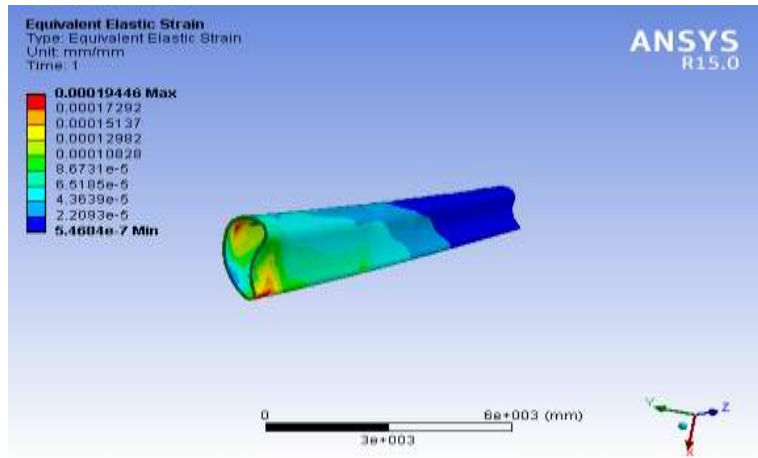

FIGURE 5. Von-misses stress in S-glass epoxy 15<sup>0</sup>twist blade angle



**FIGURE 6.**Total Deformation in S-glass epoxy 30<sup>0</sup>twist blade angle



**FIGURE 7.** Strain in S-glass epoxy 30<sup>0</sup>twist blade angle

**TABLE 2.**Static Analysis Results

	E-glass epoxy		S-glass epoxy	
	15 <sup>0</sup> angle	30 <sup>0</sup> angle	15 <sup>0</sup> angle	30 <sup>0</sup> angle
Total Deformation (mm)	41.307	39.581	14.724	14.108
Stress (Mpa)	38.515	40.901	38.42	40.106
Strain	0.00054	0.00058	0.00019	0.000203

**Dynamic Finite Element Analysis:** Dynamic finite element analysis of the blade mainly refers to the vibration modal analysis using the finite Element theory. Modal analysis is used to identify natural frequencies, especially low-order frequencies and vibration modes of wind turbine blades. From the modal we can learn in which frequency range the blade will be more sensitive to vibrate. Blades should be designed to avoid the resonance region with the tower and other components in order to prevent some destruction of related components. In this paper, the finite model of the blade has been established in ANSYS by importing the blade surface model created previously. Modal analysis is carried out to check whether the mechanical properties of the blade meet certain safety requirements.

**Modal Analysis of S-glass Epoxy30<sup>0</sup> Twist Blade Angle**

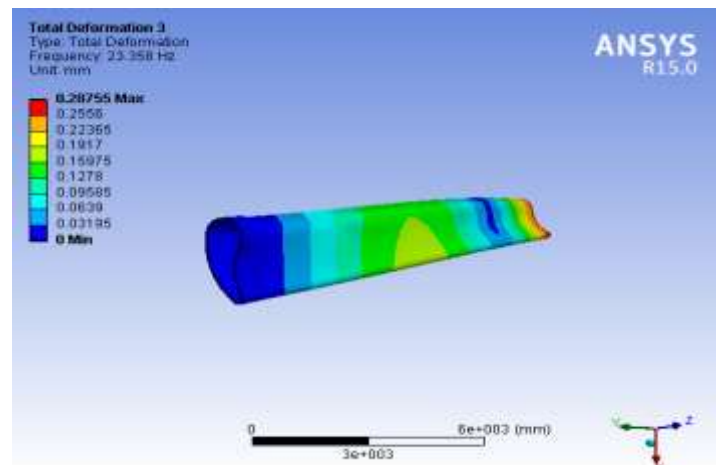
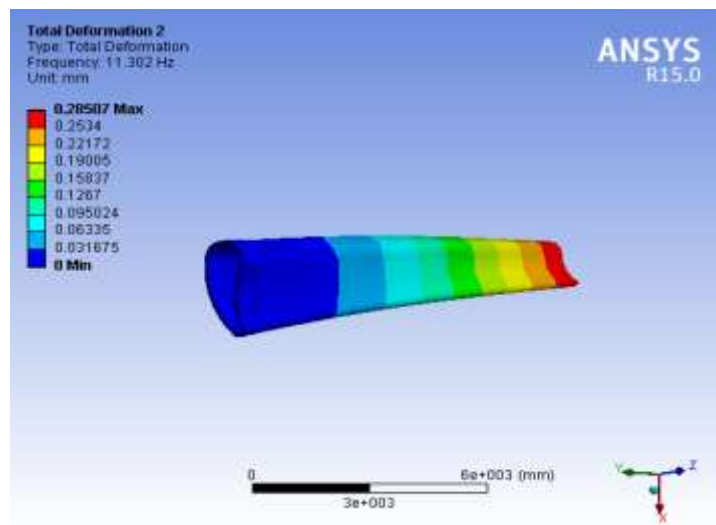
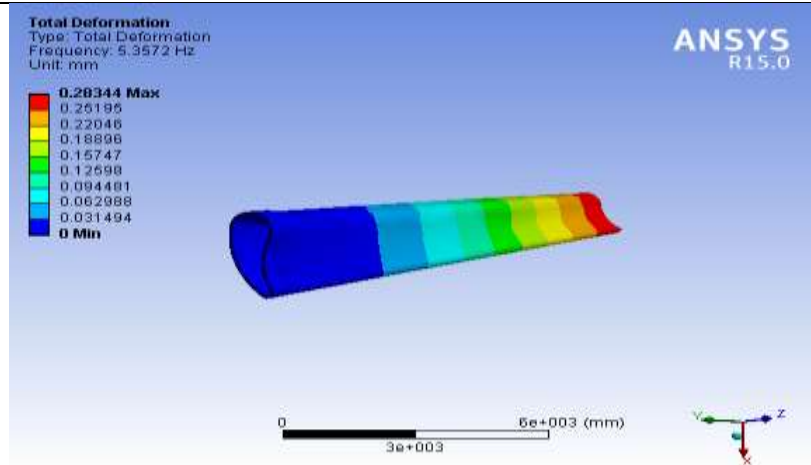

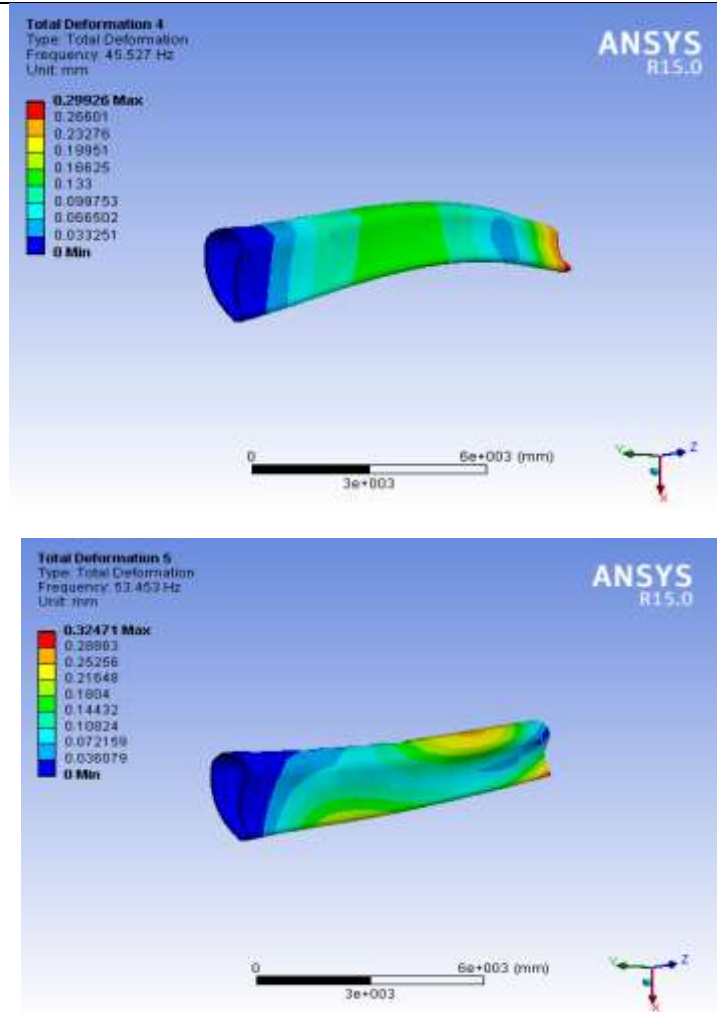

TABLE 3 Modal Analysis of Wind Turbine Blades

	E-glass epoxy		S-glass epoxy	
	15 <sup>0</sup> angle	30 <sup>0</sup> angle	15 <sup>0</sup> angle	30 <sup>0</sup> angle
mode 1 in Hz	5.6254	5.3849	5.5967	5.3572
mode 2 in Hz	11.956	11.348	11.906	11.302
mode 3 in Hz	23.834	23.466	23.728	23.358
mode 4 in Hz	48.366	45.653	48.233	45.527
mode 5 in Hz	53.015	53.272	53.121	53.453

#### 4. GRAPHS & DISCUSSIONS

According to results of structural analysis graphs are plotted for the E-glass epoxy and S-glass epoxy composite materials. Graphs are plotted for the Von-mises stress and Deformation.

##### A. Von -Mises Stress in Materials

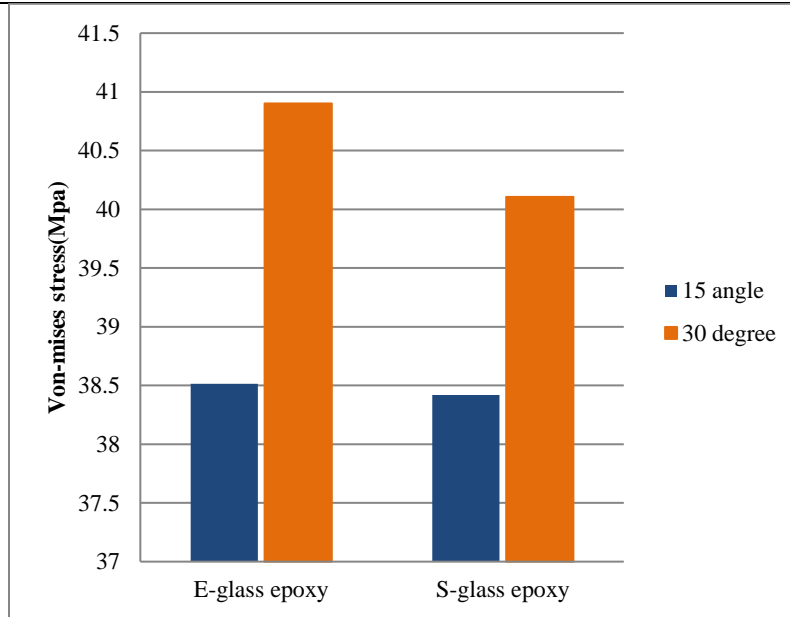

**FIGURE 8.** Von-mises Stress of Different Materials in Mpa

### B. Deformation in Materials

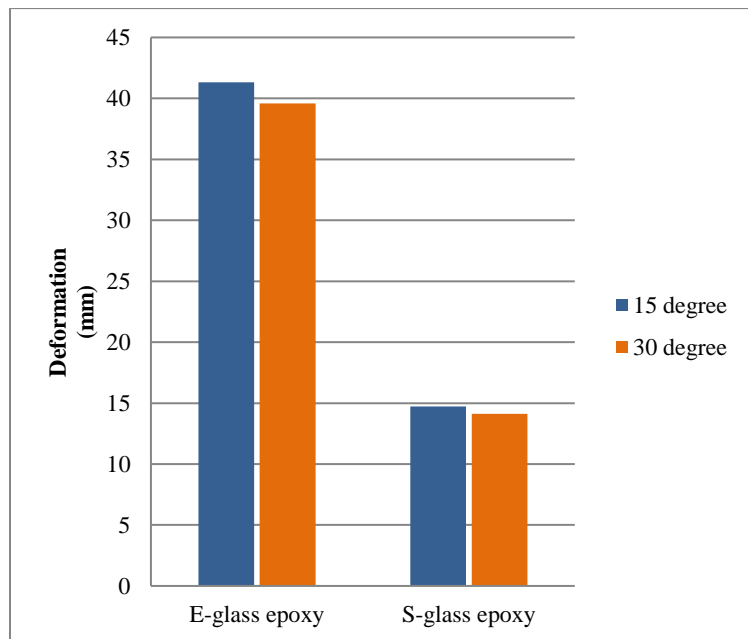

**FIGURE 9.** Deformation in Different Materials in mm

### C Strain in Materials

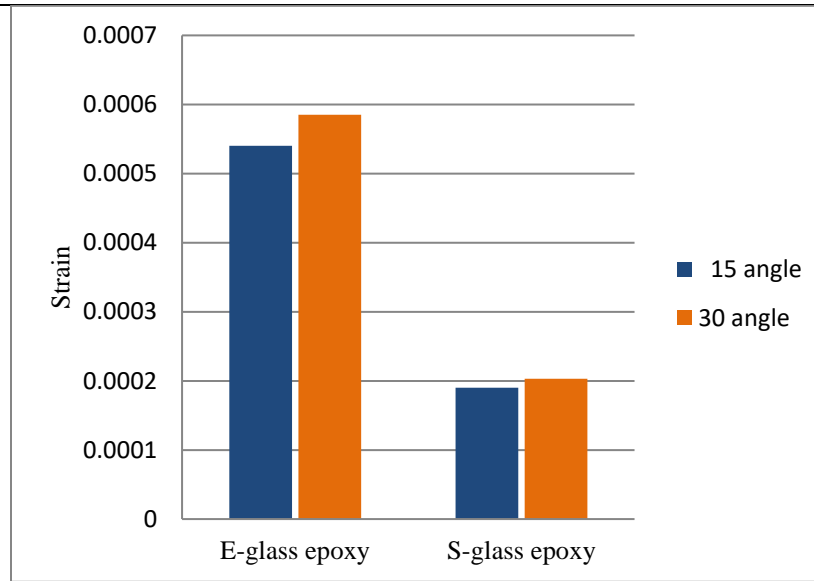

**FIGURE 10.** Strain in Different Materials

Structural analysis has been carried out on the wind turbine blades with E-glass and S-glass epoxy materials. The deformation, von-mises stress and strain are estimated at all along blade on comparison it is noticed that minimum deformation is only 14.108mm for the S-glass epoxy material against 14.724mm, 41.307mm and 39.581mm on that of S-glass epoxy 15<sup>0</sup> angle, glass epoxy 30<sup>0</sup> angle and E-glass epoxy 15<sup>0</sup> angle blades. The higher Von-mises stress value obtained for the E-glass epoxy material 30<sup>0</sup> angle. The lower Von-mises stress value obtained for the S-glass epoxy material is 38.42Mpa. The higher Strain value obtained for the E-glass material 30<sup>0</sup> angle blade is 0.000585. The lower strain value obtained for S-glass material 15<sup>0</sup> angle blade is 0.00019. ANSYS was adopted to establish the blade model so as to describe actual shape and layer structure of the blade precisely. The dynamic performance of the E-glass and S-glass epoxy blade was checked by modal analysis, providing a reference for structure design and other analyses. Hence S-glass epoxy material better compared to the E-glass epoxy material based on the total deformation, von-mises stress and strain values obtained.

## 5. CONCLUSION

This paper applied to realize the aerodynamic contour optimization design of wind turbine blade. The way of combining Pro/E and ANSYS was adopted to establish the blade model precisely. Structural analysis and Dynamic analysis has been carried out on the wind turbine blades with E-glass and S-glass epoxy materials. The dynamic performance of blade checked by modal analysis. Hence S-glass epoxy material gives better results compared to the E-glass epoxy material based on the total deformation, von-mises stress and strain values obtained.

### Scope of Future Work

The present work can be extended by sandwiched a composite material inside wind turbine blade having higher stiffness to reduce deflection in blade.

### Acknowledgment

The author would like to thank the management and HOD of mechanical engineering department, JNTUACE, for their support and assistance.

## REFERENCES

- [1]. T.Vishnuvardhan, Dr.B.Durga Prasad “Fabrication and evaluating the performance of small size wind turbine blades with R21 and R22 profiles”.
- [2]. H.Ghasemnejad, a.Maheri “Buckling analysis for design of horizontal axis wind turbine (hawt) composite blades”.
- [3]. E.N. Jacobs, K.E.Ward, & R.M. Pinkerton. NACA Report No. 460, "The characteristics of 78 related airfoil sections from tests in the variable-density wind tunnel".
- [4]. T.Vishnuvardhan, Dr.B.Durga Prasad “Finite element analysis and experimental investigations on small size wind turbine blades”.
- [5]. Kevin Cox, Andreas Echtermeyer “Inverse Design-Momentum, a Method for the preliminary design of horizontal axis wind turbines,” *Journal of Physics: Conference Series*.
- [6]. L. Fingersh, M. Hand and A. Laxson, “Wind Turbine Design Cost and Scaling Model,” Technical Report.
- [7]. P.L.N.V. Aashrith, Ch.Vikranth “Fluid dynamics wind turbine design: critical analysis, Optimization an Application of BEM Theory,” *Renewable Energy*