

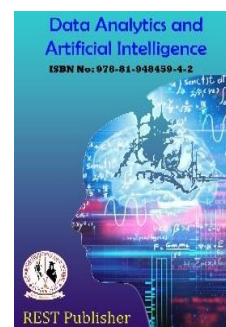

**Data Analytics and Artificial Intelligence**  
**Vol: 3(6), 2023**  
**REST Publisher; ISBN: 978-81-948459-4-2**  
**Website: <http://restpublisher.com/book-series/daai/>**



## Solar Based Reverse osmosis water purification system

**Rajesh, A. Ajith, S.Arun Kumar, S. Balamurugan, A.Veeradurai**  
 SCADCET

**Abstract-** Access to clean drinking water is a major challenge in many rural communities, particularly in areas with limited access to electricity. Traditional water treatment methods such as boiling and chlorination can be ineffective and costly. A solar-based RO water purification system offers a sustainable and cost-effective solution to this challenge by utilizing solar energy to power the water treatment process. The system design includes solar panels, a pre-treatment process, a reverse osmosis membrane, a post-treatment process, and a storage tank for the purified water. The project involves site selection, system design, installation, testing, and community engagement activities. The expected outcomes of this project include improved access to clean drinking water, reduction in waterborne diseases and health problems, a sustainable and cost-effective solution for water treatment, and increased awareness of sustainable water treatment technologies. The objective of this proposal is to design, install, and operate a solar-based RO water purification system in a rural community to provide clean drinking water to the community members. The project will involve site selection, system design, installation, operation, and community engagement activities. The solar-based RO water purification system will consist of solar panels, a pre-treatment process, a reverse osmosis membrane, a post-treatment process, and a storage tank for the purified water. The pre-treatment process will remove any large particles, sediment, and contaminants, while the reverse osmosis membrane will remove dissolved minerals and impurities. The post-treatment process will ensure that the water meets the required standards for drinking water.

**Keywords:** Solar Energy, Water purification

### 1. INTRODUCTION

Access to clean drinking water is a fundamental human right, yet it remains a significant challenge in many rural communities, particularly in areas with limited access to electricity. Traditional water treatment methods such as boiling and chlorination can be ineffective and costly, leading to waterborne diseases and health problems. Solar-based RO water purification systems offer a sustainable and cost-effective solution to this challenge by utilizing solar energy to power the water treatment process. The solar-based RO water purification system will consist of solar panels, a pre-treatment process, a reverse osmosis membrane, a post-treatment process, and a storage tank for the purified water. The pre-treatment process will remove any large particles, sediment, and contaminants, while the reverse osmosis membrane will remove dissolved minerals and impurities. The post-treatment process will ensure that the water meets the required standards for drinking water.

**International status:** Solar-powered RO system for a school in rural Kenya: This project was implemented by GivePower, a non-profit organization that provides solar-powered water desalination systems to communities in need. The system includes a 50 kW solar power plant, a 75,000 liter per day RO plant, and a 24,000-liter capacity storage tank. The purified water is used to supply a school and a health clinic, as well as for community use. Solar-powered RO system for a refugee camp in Jordan: This project was implemented by UNHCR, the UN refugee agency, to provide clean drinking water to Syrian refugees living in the Azraq camp in Jordan. The system includes a 5 kW solar power plant, a 2,500 liter per hour RO plant, and a 70,000-liter capacity storage tank. The purified water is distributed to the residents of the camp through a network of water kiosks.

**Nationalstatus:** Solar-powered RO system for rural communities in Rajasthan, India: This project was implemented by Tata Power in partnership with the Rajasthan government to provide clean drinking water to 15 remote villages. The system includes a 5 kW solar power plant, a 5,000 liter per hour RO plant, and a 5,000-liter capacity storage tank. The purified water is distributed to the villages through a network of pipelines and community taps.

**Solar Spring:** This is a larger solar-based water purification system designed for rural communities. It has a capacity of up to 5,000 liters per day and includes a pre-treatment system, reverse osmosis membrane, and post-treatment system. It is powered by a 1-kilowatt solar panel array.

**Sarvajal:** This is a network of solar-powered water purification kiosks located in rural India. Each kiosk is equipped with a pre-treatment system, reverse osmosis membrane, and post-treatment system, and has a capacity of up to 1,000 liters per day. The kiosks are powered by a combination of solar panels and grid power.

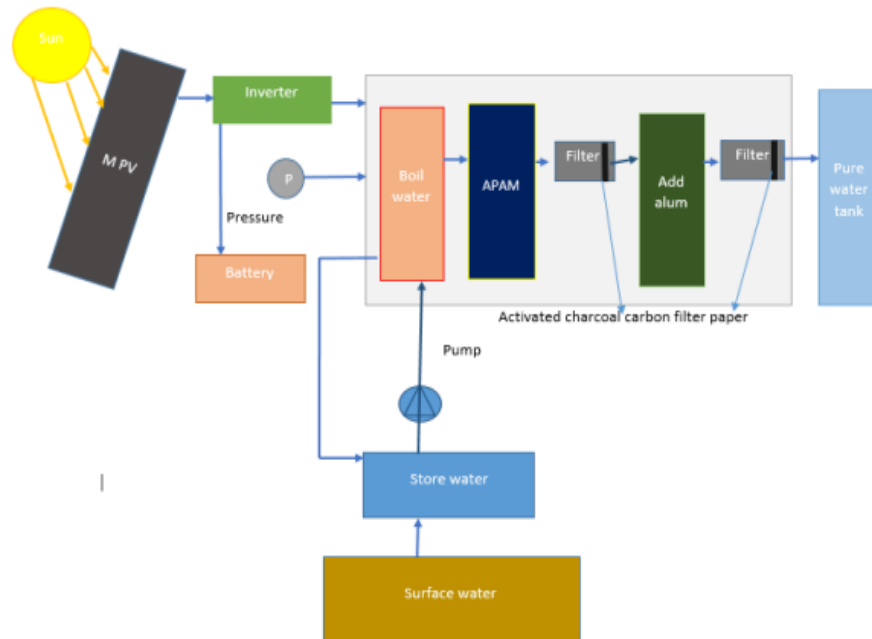

**FIGURE 1.** Solar Based Water Purification Process

**Reverse osmosis water purification stages :** A solar-based RO (Reverse Osmosis) water purification system uses solar energy to power the water purification process. The process involves several stages, including:

1. Water Intake: The water to be purified is drawn from a source, such as a well or a lake, and fed into the system.
2. Pre-Filtration: The water is then filtered to remove larger particles and debris using a pre-filter. This helps to protect the RO membrane from damage.
3. Reverse Osmosis: The water is forced through a semi-permeable membrane using a high-pressure pump. This process removes contaminants, such as dissolved salts, bacteria, and viruses, from the water.
4. Post-Filtration: After passing through the RO membrane, the water is passed through a post-filter, which removes any remaining impurities.
5. Storage: The purified water is stored in a tank for later use.
6. Distribution: The purified water is distributed through a network of pipes to various points of use, such as taps, showers, and toilets.

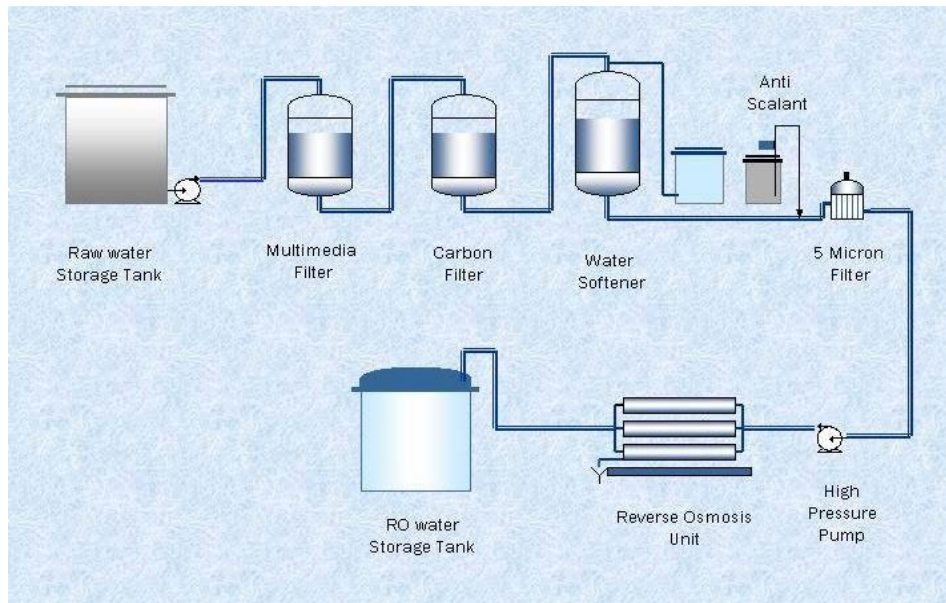

**FIGURE 2.**Reverse osmosis water purification plant

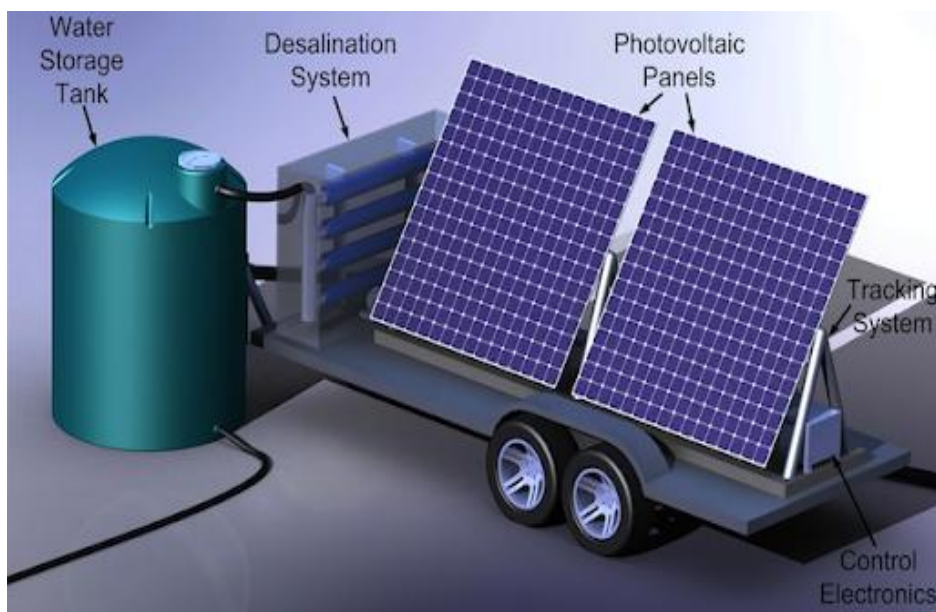

**FIGURE 3.**Solar Based RO Plant

## 2. EXISTING SYSTEM

In this system, the solar panel generates electricity which is then used to charge the battery bank through a charge controller. The DC-DC converter then regulates the voltage and current to power the DC water pump, which pumps water from the source (such as a well or a river) through pre-filtration, the RO unit, post-filtration, and finally into the storage tank. The UV sterilizer ensures that any remaining bacteria or viruses in the water are eliminated before the water is dispensed from the faucet for use. The solar panel converts sunlight into DC electricity, which is regulated and stored in a battery by a charge controller. The DC-DC converter and inverter convert the DC electricity into the required voltage for the RO water purifier.

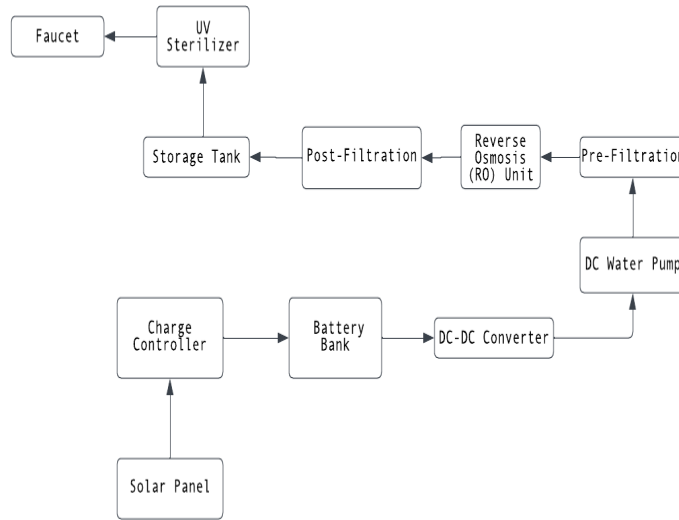

FIGURE 4.Existing System

### 3. PROPOSED SYSTEM

The solar panel generates electricity, which charges the battery. The DC-DC converter regulates the voltage and provides power to the RO unit and pump. The RO unit purifies the water by applying pressure to the feed water, which is forced through a semi-permeable membrane that removes dissolved salts, minerals, and other impurities. The pump provides the necessary pressure to force the feed water through the membrane. The monitoring system includes sensors to measure the quality of the feed water and purified water, ensuring that the system is operating efficiently. The batteries supply power to the inverter, which converts the DC power to AC power for the RO water purification unit. The RO unit purifies water and sends it to a treated water storage tank, which is equipped with a dispenser for easy access to clean drinking water. The system can also include monitoring devices and sensors to ensure efficient operation and easy maintenance.

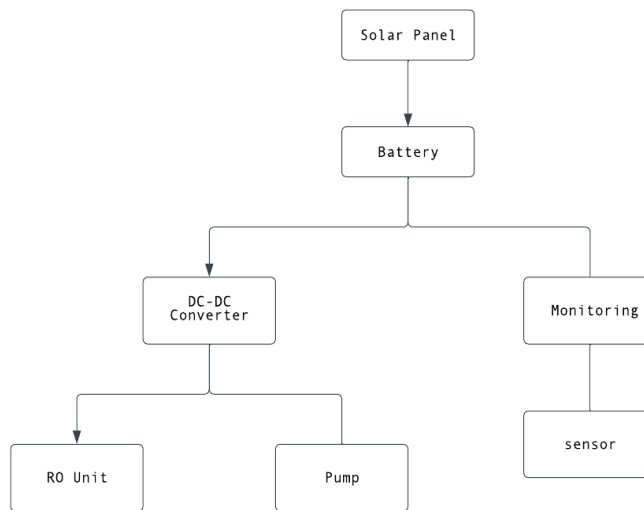
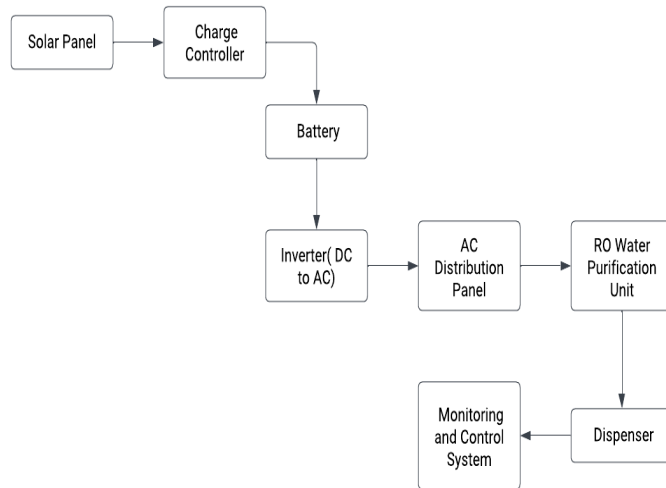

FIGURE 5.Proposed System



**FIGURE 6.**Solar Based RO Purification System

#### **4. HARDWARE COMPONENTS**

1. Solar Panel
2. Battery
3. Charge Controller
4. Reverse Osmosis (RO) Unit
5. Pre-Filter
6. Storage Tank
7. Pump
8. UV Lamp
9. Plumbing and Tubing
10. Monitoring and Control System

#### **5. WORKING OF PRINCIPLE**

Solar panels generate electricity from sunlight, which is stored in batteries. The stored electricity powers a charge controller that regulates the flow of electricity from the solar panels to the RO unit and other components. The water to be purified is first passed through a pre-filter that removes large particles, sediments, and other debris. The pre-filtered water is then pumped through the RO unit, where it passes through a semi-permeable membrane. The membrane allows water molecules to pass through while blocking impurities and contaminants like minerals, bacteria, and viruses. The purified water is stored in a tank until it is ready for use. A UV lamp is used to kill any remaining bacteria or viruses that may be present in the purified water. The monitoring and control system tracks the performance of the system and makes adjustments as necessary to ensure optimal operation.

#### **6. BENEFITES OF SOLAR RO SYSTEM**

Using solar energy to power the system reduces the cost of electricity required to operate the system, making it more cost-effective in the long run. The system uses a semi-permeable membrane to remove impurities and contaminants from water, making it highly efficient in producing clean drinking water. Solar-based RO systems are low maintenance and require minimal upkeep, reducing the overall cost of operation. The system operates independently of the power grid, making it reliable even in areas with unreliable or no electricity supply.

## 7. HARDWARE VIEW

This purifier is used for filtering process to remove the unwanted bacteria, dirt from water this process completely executes with the help of solar energy. The rotation of the motor helps to remove impurities by operating a motor that pumps water through a system of filters, pumps and hoses located in purifier.



**FIGURE 7.**Solar panel**FIGURE 8.**12V Battery



**FIGURE 9.**Charge controller**FIGURE 10.**Reverse Osmosis(RO)Unit



**FIGURE 11.**Storage Tank**FIGURE 12.**Purifier Pump



**FIGURE 13.** UV Lamp**FIGURE 14.**RO Tap

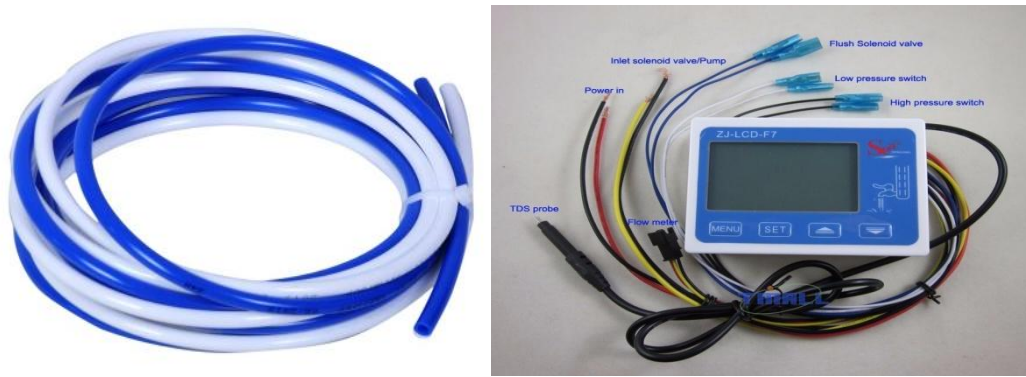

**FIGURE 15. RO Tube****FIGURE 16.RO (Monitor and Control System)**

## 8. CONCLUSION

In conclusion, a solar-based RO water purification system is an excellent solution to address the challenge of providing clean drinking water in remote areas without access to a reliable power grid. The system uses solar energy to power a series of components, including a pre-filter, an RO unit, a storage tank, and a UV lamp to produce purified water. A solar-based RO water purification system is an efficient and sustainable solution for producing clean drinking water in areas without access to a reliable power grid. By harnessing the power of the sun to generate electricity, these systems are cost-effective, environmentally friendly, and highly reliable. Overall, a solar-based RO water purification system offers many advantages, including cost-effectiveness, sustainability, portability, reliability, efficiency, and low maintenance. As a result, these systems are an excellent option for providing clean drinking water in areas without access to a reliable power grid.

## REFERENCE

1. Title: Solar powered reverse osmosis water purification system using single basin solar still Authors: M. A. Eltawil and Z. Zhengming Journal: Renewable Energy Volume: 33 Issue: 11 Year: 2008 Pages: 2469-2475
2. Title: A solar-powered water desalination system using reverse osmosis membrane Authors: N. Ramesh Babu, T. P. Melo, K. L. Wasewar, and D. B. M. Kumar Journal: Desalination Volume: 259 Issue: 1-3 Year: 2010 Pages: 129-135
3. Title: A solar-powered reverse osmosis system for rural water supply in India S. N. Singh, N. K. Singh, and M. P. Singh Journal: Desalination Volume: 284 Pages: 336-342 Year: 2012
4. Title: Solar-powered reverse osmosis desalination systems: A review Authors: H. Al-Karaghoul and M. Kazmerski Journal: Renewable and Sustainable Energy Reviews Volume: 24 Year: 2013 Pages: 343-356
5. Title: Design of a solar-powered reverse osmosis desalination plant in Egypt Authors: K. Abdel-Malek and A. Younes Journal: Renewable and Sustainable Energy Reviews Volume: 31 Year: 2014 Pages: 364-373
6. Title: Development and experimental investigation of a solar-powered reverse osmosis water purification system Authors: S. S. Sahoo, S. Panda, and S. K. Sahoo Journal: Journal of Renewable and Sustainable Energy Volume: 6 Year: 2014 Pages: 013101
7. Title: A solar-powered reverse osmosis desalination system for remote rural areas Authors: R. D. Dharaskar, N. B. Dandekar, and A. M. Barve Journal: Desalination and Water Treatment Volume: 56 Year: 2015 Pages: 3064-3074
8. Title: "Design and Fabrication of Solar Based Portable RO Water Purification System," by S. S. Kulkarni and P. R. Patil, published in the International Journal of Engineering and Technology, 2015
9. Title: "Design and Optimization of a Solar-Powered Reverse Osmosis Desalination System for Rural Areas in Egypt," by A. H. Abdelrahman, E. M. Taniguchi, and M. A. El-Amin, published in the International Journal of Energy and Environmental Engineering, 2016.
10. Title: "Design and experimental investigation of a standalone solar photovoltaic powered reverse osmosis water purification system" by V. K. Sharma et al. (2016)
11. Title: "Design and optimization of a solar powered reverse osmosis water purification system" by M. A. Alghoul et al. (2017).
12. Title: "Design and optimization of a solar powered reverse osmosis water purification system" by M. A. Alghoul et al. (2018)
13. Title: "Solar-powered reverse osmosis system: An innovative solution for rural areas" by M. Shahzad et al. (2018)
14. Title: "Design and experimental investigation of a standalone solar powered reverse osmosis water purification system" by A. T. Al-Salaymeh et al. (2019)

15. Title:"Development of a solar-powered reverse osmosis water purification system for rural areas" by S. S. M. S. Perera et al. (2019)
16. Title:"Design and performance evaluation of a standalone photovoltaic-powered reverse osmosis system for drinking water production" by M. Elsayed et al. (2020)
17. Title:"Design and optimization of a solar-powered RO water treatment system for rural communities" by A. O. Adedokun et al. (2020)
18. Title:"A comparative study of energy consumption and cost analysis of solar-powered and conventional RO systems for drinking water supply" by T. Islam et al. (2021)
19. Title:"Solar-driven water purification for sustainable agriculture in remote areas" by S. M. Alzahrani et al. (2021)