

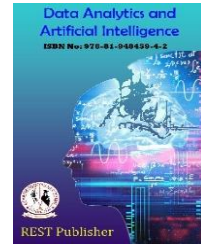

**Data Analytics and Artificial Intelligence**  
**Vol: 3(6), 2023**  
**REST Publisher; ISBN: 978-81-948459-4-2**  
**Website: <http://restpublisher.com/book-series/daai/>**



## **IOT Based Smart Energy Meter in Three Phase**

**S. Mohamed Sheik Buhari, M. Mohamed Jakeer, K, Mani Bharathi**

*SCAD College of Engineering and Technology, Cheranmahadevi, Tamilnadu, India*

**Abstract:** *Remote analysis of the IoT-connected devices is possible. Electricity is being used for a variety of purposes, including agriculture, industries, household use, hospitals, and others, at a steady rate by the population today. As a result, managing requirements and maintenance for electricity is becoming increasingly challenging. Internet of Things (IoT) presents an efficient and cost-effective method for wirelessly transferring information about energy consumers as well as provides the capability to detect the usage of electricity. The system's connectivity to the internet is provided by the ESP-8266 Wi-Fi module. As a result, there is an immediate need to conserve as much electricity as possible. The number of units and the price that goes with them are calculated and shown on the 16x2 LCD Display module. The Web of things (IoT) idea empowers us to append the customary everyday gadgets with each other over the web.*

### **1. INTRODUCTION**

The web (Internet) connects hardware devices to one another of units and the comparing cost are determined. For energy meter, the ZMPT101B voltage sensor and current sensor are interacted with a microcontroller. A SMART ENERGY METER is the name given to a device that can perform all of these functions with a single energy meter. An Arduino Uno serves as the system's central controlling unit. the voltage, current, and power consumption readings, no. Because this small module lets the microcontroller connect to the Wi-Fi network, the Wi-Fi unit plays the most important role in sending controller data over the internet. The system is built on an ESP-8266. It has full TCP/IP protocol stack and microcontroller capabilities and is a lowcost wifi microchip. Additionally, we have dealt with a number of other issues, such as power theft, which has resulted in successive economic losses for the nation. A new technology-based energy meter with three main goals that uses a Wi-Fi system. The Arduino software's Integrated Development Environment (IDE) is used to program the ESP8266 controller. The Internet of Things (IoT) concept provides the necessary infrastructure and opportunities for connecting the real world to computer-based systems. the effort required to collect readings from utility meter readings. At the same time that the demand for electricity from younger generations is rising, technological advancement is also required. The primary objective of this project is to use IOT to measure and price electricity consumption. Because it takes time and manpower, taking meter readings and calculating bills manually is a difficult task for officials of the electricity board. The primary objective of this project is to use the Internet of Things (IoT) to automatically measure electricity consumption in home appliances and generate their bills. the voltage, current, and power consumption readings, no. The proposed framework gives a 180 degree specialized bend to the customary energy meters utilizing IoT innovation.

### **2. LITERATURE SURVEY**

Design and Implementation of IOT Based Smart Energy Meter Author name: Saikat Saha, Swagata Mondal Year: 2018 This paper presents contribution reports the design, fabrication and implementation of a smart energy meter, which utilizes the features of embedded systems. Arduino microcontroller with Wi-Fi modem have been used to introduce 'Smart' feature in a traditional domestic energy meter. The IoT based smart energy meter developed in this work enables the electricity supply authority to read the meter regularly without physically visiting each house. This has been achieved by the use of Arduino unit that continuously monitor and records the energy meter reading in its memory. With the use of Wi-Fi modem, the meter is made to communicate with the internet making the system a part of IoT. Using this smart energy meter, the consumer as well as service provider will be able to view and read get the used energy pattern along with the respective amount. The meter is able to record and send voltage, current, energy, power, and power factor. All these parameters are visible in both webpage and Android mobile app. Through such detailed record of events, the service provider can keep track of the energy consumption

pattern enabling better and efficient load forecasting and management. On the other hand, the billing system will become more transparent to the consumer. Smart energy meter surveillance using IOT

Author name: Anitha.k, Prathik Year: 2019 In this paper about internet of things as an emerging field and IoT based devices have created a revolution in electronics and IOT. The foremost objective of this project is to create awareness about energy consumption and efficient use of home appliances for energy savings. Due to manual work, existing electricity billing system has major drawbacks. This system will give the information on meter reading, power cut when power consumption exceeds beyond the specified limit using IoT. The Arduino esp8266 micro controller is programmed to perform the objectives with the help of GSM module. It is proposed to overcome all the disadvantages in the already existing energy meter. All the details are sent to the consumer's mobile through the IoT and the GSM module and it is also displayed in the LCD. It is a time savings and it helps to eliminate the human interference using IoT

3. Title: ARM-based Energy management system using smart meter and Web server  
 Author name: Landi.C Year: 2011 This paper presents about a lowcost real-time ARM-based energy management system. An integrated Web Server helps to collect the statistics of energy consumptions, power quality and is to interface devices for load displacement. The device is used to access the information. In this way it is possible to manage the power consumption of the power system leading to a consumption of power.

4. Title: Design and implementation of Bluetooth energy meter  
 Author name: Koay.B.S , Cheah.S.S Year: 2003 In this paper digital meter has started to replace the electromechanical meters in Singapore. A wireless digital power meter would offer greater convenience to the meter reading task. Bluetooth technology is a possible wireless solution to this issue. The power reader can collect the power consumption reading from the energy meter wirelessly based on Bluetooth. Two methods that can retrieve the meter reading with little human intervention, are added and implemented in the targeted applications, they are Automatic meter reading(AMR) and the Automatic polling mechanism(APM). Some commercial applications are applied for the Bluetooth-enabled energy meter.

5. Title: Smart Power Monitoring Using IoT  
 Author name: Devadhanishini Year: 2019 In this paper, that energy Consumption is the very important and challenging issue. Automatic Electrical Energy meter is used in large electric energy distribution system. The integration of the Arduino WIFI and SMS provides the system as Smart Power Monitoring system. Smart energy meter provides data for optimization and less the power consumption. This system also includes a motion sensor such that if there is no human in house or house it will automatically turn off the power supply.

### 3. EXISTING SYSTEM

This system uses Arduino microcontroller as the main controlling unit. The functions of this project are an energy meter with digital display using IoT. For energy meter the microcontroller is interfaced with a voltage sensor (ZMPT101B) and a current sensor (AC3R6). The values are noted and the units are measured with the corresponding values and thus price is calculated. The output obtained is shown on the 16\*2 LCD module. The readings collected is sent to the cloud storage over Wi-fi, where it is recorded and analyzed in graphical form. Loads are connected to the relay module with IoT based Web through mobile over Wi-Fi. Arduino is given its working power (5V) and it is interfaced with ZMPT101B voltage sensor calibrated to measure voltage up to 250V along with AC3R6 current sensor sensing up to 30A of current. The mainline wires are connected to the sensors and the readings from voltage and current sensors are noted on the serial

monitor. The number of units and the price is calculated by:-

$$\text{Power (kilowatts)} = (V_{rms} * I_{rms}) / 1000$$

$$\text{Units} = \text{Power} * (3/3600) \text{ Rupees} = \text{Units} * 2$$

The output is shown on the LCD module and the output collected is sent over the Wi-Fi module to cloud storage where it is observed, analyzed and represented in a graphical manner. The Arduino is interfaced with the relay module which is an electromechanical switch used to monitor loads with high power are operated by the web on mobile. It is connected to the micro- controller over the ESP8266 Wi- Fi module.

### 4. PROPOSED SYSTEM

Figure 1 depicts the IOT-based smart energy meter system. The 16\*2 LCD module displays the obtained output. This uses IoT to connect the local router, and the parameters' status can be viewed on a mobile device or laptop. A Wi-Fi device with a microcontroller inside is the NodeMCU. The primary controlling unit of this system is the Arduino Uno microcontroller. The microcontroller is connected to the relay module, which is connected to all of the loads.

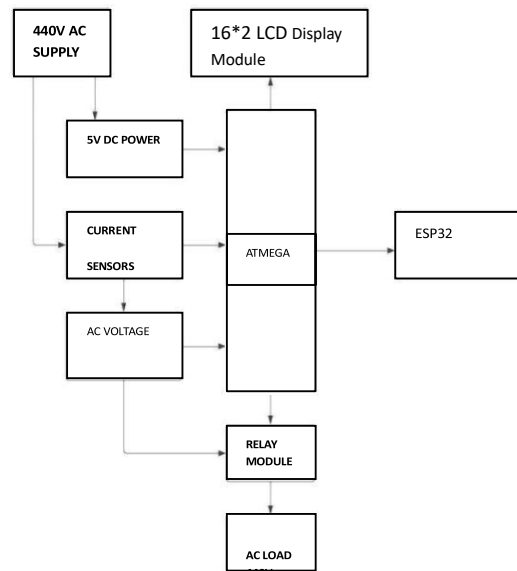

**FIGURE 1.** Proposed System

Data transmission is accomplished via WIFI. The system makes use of SMPS to transform the 5V DC power supply into the 440V AC power supply. Arduino is used to configure WiFi. The sensors are connected to the mainline wires, and the serial monitor records the voltage and current sensor readings. Price is calculated after the values are recorded and the units are measured using the values that correspond to them. A voltage sensor and a current sensor are connected to the microcontroller via an interface. The AC voltage and current are then to be measured by the voltage and current sensor. Arduino, SMPS, wifi module, voltage and current sensors, relay, and LCD display are all included in the block diagram.

## 5. HARDWARE COMPANENTS

### SMPS

A SMPS (Switched mode power supply) is an electronic power supply that incorporates a switching regulator to convert electrical power efficiently. The switching mode power supply for the isolation industrial grade built in power supply over current protection and short circuit full protection, AC110~240V wide voltage input, high and low voltage isolation, DC12V/1000m A and DC5V/500m A dual isolated output voltage, with input and output EMI filter circuit, with mounting holes. This SMPS is especially designed to interface directly with arduino and sensors.

### SMPS BLOCK DIAGRAM



**FIGURE 2.** Smps Block Diagram

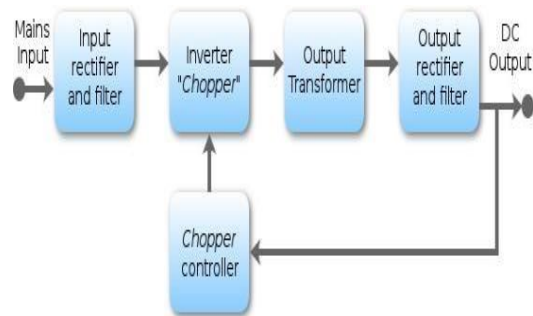

**FIGURE 3.** Block Diagram of SMPS

Switched Mode Power Supply uses a switching regulator to convert electric power efficiently. SMPS transfers electric power from a source (AC mains) to the load by converting the characteristics of current and voltage. SMPS always provide a well-regulated power to the load irrespective of the input variations. SMPS incorporates a Pass transistor that switches very fast typically at 50Hz and 1 MHz between the on and off states to minimize the energy waste. SMPS regulates the output power by varying the on to off time using minimum voltage so that efficiency is very high compared to the linear power supply.

## Arduino



**FIGURE 4.** Arduino

### Arduino Uno

The Arduino UNO is a standard board of Arduino. Here UNO means 'one' in Italian. It was named as UNO to label the first release of Arduino Software. It was also the first USB board released by Arduino. The Arduino UNO board is mostly used by the beginners that can use in electronics project and do programming in this board. The board has regular innovation and a bug fix in the design of the board to make the board suitable for the project's use. It is considered as the powerful board used in various projects. Arduino.cc developed the Arduino UNO board. Arduino UNO is based on an ATmega328P microcontroller. It is easy to use compared to other boards, such as the Arduino Mega board, etc. The board consists of digital and analog Input/Output pins (I/O), shields, and other circuits. The Arduino UNO includes 6 analog pin inputs, 14 digital pins, a USB connector, a power jack, and an ICSP (In-Circuit Serial Programming) header. It is programmed based on IDE, which stands for Integrated Development Environment. It can run on both online and offline platforms. The IDE is common to all available boards of Arduino. Sensors are used with Arduino board such as temperature sensor, rain sensor, LPG gas sensor it may be analog or digital sensors. We can take the output by programming whatever for the output like display, motor running, relay on and off so that light fan can be controlled. You can do a lot more than this with the Arduino board

## Pin Diagram

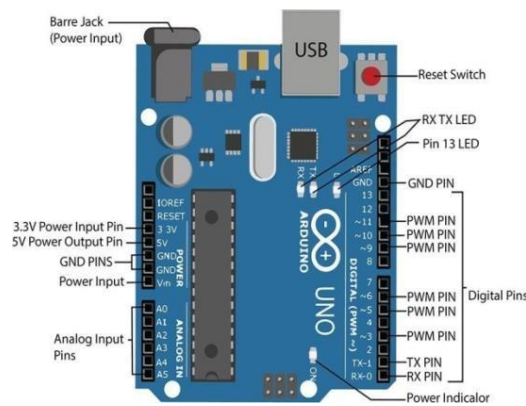

FIGURE 5. Pin Diagram

## Pin Diagram

- ATmega328 Microcontroller- It is a single chip Microcontroller of the ATmel family. The processor code inside it is of 8-bit. It combines Memory (SRAM, EEPROM, and Flash), Analog to Digital Converter, SPI serial ports, I/O lines, registers, timer, external and internal interrupts, and oscillator.
- ICSP pin - The In-Circuit Serial Programming pin allows the user to program using the firmware of the Arduino board.
- Power LED Indicator- The ON status of LED shows the power is activated. When the power is OFF, the LED will not light up.

Digital I/O pins- The digital pins have the value HIGH or LOW. The pins numbered from D0 to D13 are digital pins.

- TX and RX LED's- The successful flow of data is represented by the lighting of these LED's.
- AREF- The Analog Reference (AREF) pin is used to feed a reference voltage to the Arduino UNO board from the external power supply.
- Reset button- It is used to add a Reset button to the connection.
- USB- It allows the board to connect to the computer. It is essential for the programming of the Arduino UNO board.
- Crystal Oscillator- The Crystal oscillator has a frequency of 16MHz, which makes the Arduino UNO a powerful board.
- Voltage Regulator- The voltage regulator converts the input voltage to 5V.
- GND- Ground pins. The ground pin acts as a pin with zero voltage.
- Vin- It is the input voltage.
- Analog Pins- The pins numbered from A0 to A5 are analog pins. The function of Analog pins is to read

the

It can also act as GPIO (General Purpose Input Output) pins.

### Advantages Of Arduino:

Not much knowledge required to get started.

Fairly low cost, depending on shields you need.

Lots of sketches and shields available.

No external programmer or power supply needed

### Applications Of Arduino

Weighing Machines.

Traffic Light Count Down Timer.

Parking Lot Counter.

Embedded systems.

Home Automation.

Industrial Automation.

Medical Instrument.

Emergency Light for Railways.

**ESP32 Module:****FIGURE 6.** ESP32 Module

The ESP32 is a low-cost System on Chip (SoC) Microcontroller from Espressif Systems, the company behind the well-known ESP8266 SoC. It is the successor to the ESP8266 SoC and is available in single-core and dual-core versions of the 32-bit Xtensa LX6 Microprocessor from Tensilica, which has integrated Bluetooth and Wi-Fi. Like the ESP8266, the integrated RF components of the ESP32, such as the Power Amplifier, Low-Noise Receive Amplifier, Antenna Switch, Filters, and RF Balun, are advantageous. Because you only need a small number of external components, designing hardware for the ESP32 is a breeze. The fact that the ESP32 is manufactured using TSMC's ultra-low-power 40 nm technology is another important fact to know about it. Along these lines, planning battery worked applications like wearables, sound gear, child screens, savvy watches, and so on., utilizing ESP32 ought to be extremely simple. Let's take a look at an application for ESP32 now that you have a good understanding of it. I don't feel like I need to tell you much in this chapter. You should have started thinking of ideas in your head after reading the various chapters in this tutorial. You should already have a rough list of potential applications for the ESP32. The good news is that most of the applications that you have listed can be done. ESP32, on the other hand, is more practical for some applications than others. In this chapter, I will try to explain the considerations you should make when deciding whether or not to use ESP32 in your application. Please be aware that this chapter is focused on production, referring to the number of thousands or lakhs of devices. If you have an ESP32, this is the upgraded version of the ESP8266. It has 34 GPIO pins and a 160 MHz Xtensa dual-core processor. The ESP32 has multiple input/output connectors, including digital-to-analog converters, and a 32-bit processor with an ultra-low power co-processor. The secure platform for the Internet of Things is provided by the ESP32. Access to a remote control and a temperature sensor are provided by the ESP32. Secure boot flash encryption of 1024 bits OTP with PWM (soft) 16 is provided by the ESP32. Ten touch sensors are in the ESP32. The ESP32 is superior to ESP8266. It lets you design significantly larger projects on a single SOC thanks to its faster processor and large memory. You get high-tech security from the ESP32. ESP32 is unique in its strong security feature. The board, firmware, and peripherals of the ESP32 are dependable. In the world of IoT, secure socket layer connections are made possible by the processing power, and ESP32 devices have more GPIOs to work with more complex and useable projects. It is better suited for any application that requires a microcontroller. It is said that the ESP32 development board is very capable and that many of them come with small cameras. The development power of the ESP32 enables projects to have more RAM and better security,

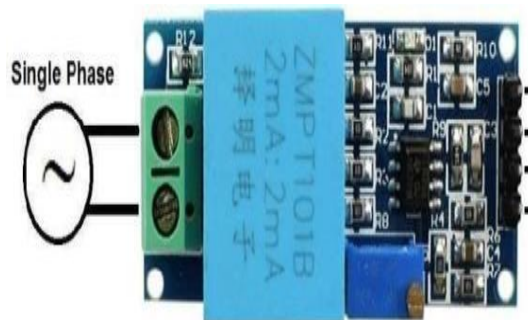
**Voltage Sensor:****FIGURE 7.** Voltage sensor



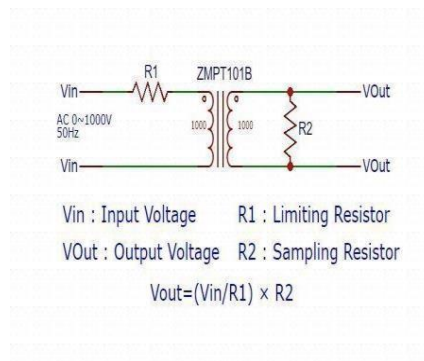

**FIGURE 8.** Zmpt101b Wiring Diagram

**ZMPT101B Wiring Diagram ZMPT101B AC**

Voltage Sensor is the best for the purpose of the DIY project, where we need to measure the accurate AC voltage with voltage transformer. ZMPT101B is an ideal choice to measure the AC voltage using Arduino/ESP8266/Raspberry Pi like an opensource platform. In many electrical projects, engineer directly deals with measurements with few basic requirements like

- High galvanic isolation
- Wide Range
- High accuracy
- Good Consistency

ZMPT101B is a high precision voltage Transformer. This module makes it easy to monitor AC mains voltage upto 1000 volts. A tiny little thing the size of a bouillon cube. Holds up to 4kV per breakdown voltage, the ratio of turns is 1: 1, but this is a current transformer of 2mA: 2mA. That is, we feed it a current and remove the current. The input current is simply set by the resistor in series R1, and a sampling resistor R2 is used in parallel to obtain the output voltage.

**FEATURES of ZMPT101B**

**Voltage Sensor**

- Voltage upto 250 volts can bemeasured □
- Light weight with on- board micro-precision voltage transformer □
- High precision on-boar □ d op-amp circuit □
- Operating temperature: 40°C ~ +70°C □
- Supply voltage 5 voltsto 30 volts

**ADVANTAGES of ZMPT101B Voltage Sensor**

- Analog output corresponding quantity can beadjusted. □
- Pcb board size : 49.5 (mm) x19.4(mm) □
- Good consistency, for voltage and power measurement □
- Very efficient and accuracy □

**CURRENT SENSOR**



**FIGURE 9.** Current sensor

**current sensor**

A current sensor is a device that detects and coverts current to an easily measurable output voltage, which is

proportional to the current through the measured path. Onboard precision micro current transformer, which can transform AC signal of large current into small amplitude signals. The maximum current that can be reach 5A and the present current signal can be read via analog I/O port. The sensor works when the current conductor passes through a magnetically permeable core that concentrates the conductor's magnetic field. The Hall effect device, which is mounted within the core, is at a right angle to the concentrated magnetic field and a constant current (in one plane) excites the Hall device. A current sensor is a device that detects and converts current to an easily measurable output voltage, which is proportional to the current through the measured path. There are a wide variety of sensors, and each sensor issuitable for a specific current range and environmental condition. The maximum AC or DC that can be detected can reach 5A, and the present current signal can be read via analog I / O port of a microcontroller or an Arduino.

### Circuit Diagram

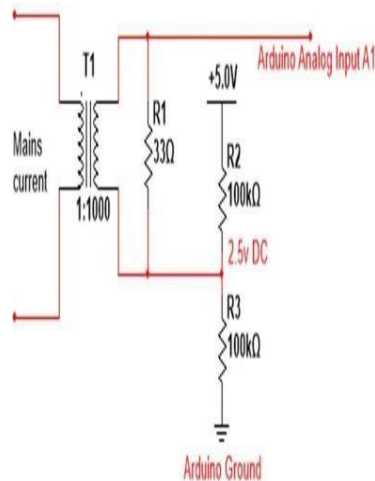

FIGURE 10. Circuit Diagram

Circuit Diagram The current signal flowing through mains is retrieved through a current sensor. A burden resistor transformer the cuurent signal into a voltage from the represents the properties of the current sinusoid. A DC offset voltage of 2.5v is applied to the sinusoidal signal so that the references point is lifted up and the whole sinusoid can be read in analog mode within its operating range (0.5).

#### Specification:

- Onboard precision micro current transformer.
- Onboard sampling resistor.
- The module can measure AC current less than 5 amps.
- The corresponding analog output 5A/5m A. PCB dimension (L\*W\*H in mm) : 28\*1.5\*38.5mm.

#### Advantages Of Current Sensor:

- Measurement of DC and AC current without any additional losses.
- Wide frequency range.
- Low system cost.
- No remanence in the event of overload.
- Smaller volume and weight.

#### Application Of Current Sensor:

- Device are used for power metering.
- Control system diagnosis.
- Current supply measurement.
- Control of complex load from electric motors.
- Charge integration and condition monitoring of rechargeable batteries.



## LCD DISPLAY



FIGURE 11. LCD Display

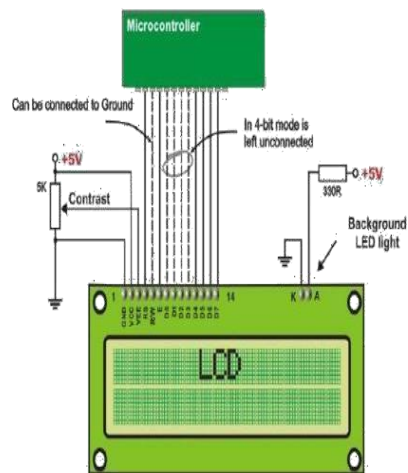

FIGURE 12. LCD Display

LCD Display Liquid Crystal Displays (LCDs) have materials, which combine the properties of both liquid and crystals. Rather than having a melting point, they have a temperature range within which the molecules are almost as mobile as they would be in a liquid, but are grouped together in an ordered form similar to a crystal. An LCD consists of two glass panels, with the liquid crystal materials and witted in between them. The inner surface of the glass plates are coated with transparent electrodes which define the character, symbols or patterns to be displayed polymeric layers are presenting between the electrodes and the liquid crystal, which makes the liquid crystal molecules to maintain a defined orientation angle. One each polarizer are pasted outside the two glass panels. This polarizer would rotate the light rays passing through them to a definite angle, in a particular direction. When the LCD is in the off state, light rays are rotated by the two polarity the liquid crystal, such that the light rays come out of the LCD without any orientation, and hence the LCD appears transparent.

When sufficient voltage is applied to the electrodes, the liquid crystal molecules would be aligned in a specific direction. The light rays passing through the LCD would be rotated by the polarizer, which would result in activating/high lighting the desired chaThe LCDs are light weight with only a few millimeters thickness. Since the LCD's consume power, they are compatible with low power electronic circuits, and can be powered for long durations. The LCD does don't generate light and so light is needed to read the display. By using backlighting, reading is possible in the dark. The LCD's have long life and a wide operating temperature range. Changing the display size of the layout size is relatively simple which makes the LCD's more customers friendly. The LCD's used exclusively in watches, calculators and measuring instruments are the simple seven-segment displays, having a limited amount of numeric data. There sent advances in technology have resulted in better legibility, more informationdisplaying capability and a wider temperature range. The LCDs have even started replacing the cathode ray tubes (CRTs) used for the display of text and

graphics, and also in small TV applications. LCD display use of our project title message and information message. Our project connect to a microcontroller unit data line connected to a 'PORT2' and control lines connected to a P3.5, P3.6, P3.7.

## Relay



FIGURE 13. Relay

The three high-voltage terminals (NC, C, and NO) that connect to control make up the relay. Additionally, three low-voltage pins (ground, Vcc, and signal) connect the relay to the Arduino. The 120-240 switches inside a relay are connected to an electromagnet. A blue-colored plastic 5V relay sits at the center of the module. The relay cover's top also lists the maximum operating current and voltage for both AC and DC loads. The part number, SRD-05VDC- SL-C, indicates the operating voltage. The term for it is a 5V relay module. because 5V DC is used by the relay. To put it another way, a 5V active high or low signal powers up the relay's coil. A coil, the NC, NO, and COM terminals, are the internal components of a 5V relay, as previously mentioned. The Single Channel Relay Module is a useful board that can be used to control loads with a high voltage and a high current, such as motors, solenoid valves, lamps, and AC loads. It is made to work with microcontrollers like Arduino, PIC, and others. A single relay that can be controlled by any microcontroller's 5V digital output is provided by the 1 Channel 5V Relay Module. The relay can handle up to 2A of current and has screw terminals for access. A helpful Drove shows the situation with the transfer. Signal pin : The relay is controlled by it. This pin can be active high or low. In the event of dynamic low, the hand-off will enact when we apply a functioning low sign to the sign pin. On the other hand, when we apply an active high signal to the signal pin in the case of an active high, the relay will turn on. However, these modules typically function with an active high signal. The relay coil will be energized by this signal to make contact with the normally open common terminal. VCC Number: It is a 5V relay, as its name suggests. This implies that it requires 5V DC to function. As a result, connect this pin to the 5 volt DC power supply. The Ground Pin: Connect it to the 5V power supply's ground terminal. Moreover, in the event that you are driving a transfer module with a microcontroller, likewise interface this pin with the ground terminal of the microcontroller. The Common Pin This terminal is associated with our desired burden to switch with the transfer module. NC Pin : The normally close terminal, as its name suggests, is typically connected to the COM pin to form a closed circuit. However, when a microcontroller applies an active high or active low signal to the signal pin of the relay module, this normally closed connection breaks. NO Pin : Unless we apply an activation signal to the signal pin of the 5V single channel relay module, this pin is normally open. The COM pin makes a connection with the NO pin in this instance, breaking its connection with the NC pin.

### Specification:

The maximum voltage allowed is: Rated current: 5 volts 0.1A

- Transfer contact current limit at AC 250V/7.5A
- Transfer contact current limit at DC 14V/7A

Transfer trigger sort APPLICATION Home Automation Projects Switching **an AC** voltage load from low voltage DC current Electrical isolation between low and high power sources Motors speed control with start-delta converters Under and over voltage protection system Low-level trigger Power indication Input signal indication Output signal indication Directly connect to MCU output port With diode current protection.

### Advantages Of Relay:

Isolation and Separation of Circuits, Small Size, Easy Troubleshooting, Control of More Than One Component, Low-Cost Components, Ease of Installation, and Ease of Cable Termination are just a few of the advantages of a relay's operation.

## 6. CONCLUSION

The IoT-based smart electricity meter has a bright future thanks to cutting-edge technology. The customer can check the price and consumed unit at any time with this system. The Wi-Fi module and embedded microcontroller improve wireless data transmission stability. In this paper, a smart energy meter system based on IoT was suggested. In general, homes that intend to monitor their power consumption and alter their behavior in response can benefit financially from smart meters. Every field's technological advancement is a never-ending process. The system has a lot of big advantages, like wireless data transmission, less work, and less money. Additionally, the system would provide a straightforward method for collecting the meter reading without the need for human intervention, which can aid in cost and usage management. The application of the "IOT BASED SMART ENERGY METER" is practically described in this project.

## REFERENCES

- [1] Anitha.k ,prathik, "Brilliant Energy Meter reconnaissance Utilizing IoT", Organization of Electrical and Hardware Engineers(IEEE), 2019.
- [2] "Smart Power Monitoring Using IoT," presented at the 5th International Conference on Advanced Computing & Communication Systems (ICACCS) in 2019, by Devadhanishini, et al.
- [3] "Design and Implementation of an Internet of Things Based Smart Energy Metering," presented at the 6th IEEE International Conference on Smart Energy Grid Engineering in 2018, by Mohammad Hossein Yaghmaee.
- [4] Himanshu kpatel "arduino based shrewd energy meter" second Int'l Conf. on 2018's ICEEICT (Electrical Engineering and Information and Communication Technology) conference.
- [5] The paper "smart meter using IoT" proposed by "Bibek Kanti Barman, et al." was published in 2017 by the Department of International Electronics and Electrical Engineering (IEEE).
- [6] "Design and Implementation of IoT Based Smart Energy Meter" presented at the 2018 IEEE Applied Signal Processing Conference (ASPCON) by Saikat Saha, Swagata Mondal, Anindya Saha, and P. Purkait
- [7] "An IoT Based Smart Energy Management System," presented at the 2018 Fourth International Conference on Computing, Communication, and Automation (ICCCA), by Jai Krishna Mishra, Shreya Goyal, and Vinay Anand Tikkiwal
- [8] "IoT Based Smart Energy Meter," by B. K. Sahani, T. Ravi, A. Tamboli, and R. Pisal, International Research Journal of Engineering and Technology (IRJET), Vol. 04, No. 04, 2017, pp. 96 – 102.